

NWS - 4 & 2
 SPEED BRAKE - 4 & 2
 ATC - 4 & 2
 PITCH TRIM - 4 & 2
 LEFT DUCT DOOR - 4
 RIGHT DUCT DOOR - 2
 LEFT THROTTLE - 4
 RIGHT THROTTLE - 2
 CROSS CHANNELS - 1 & 3

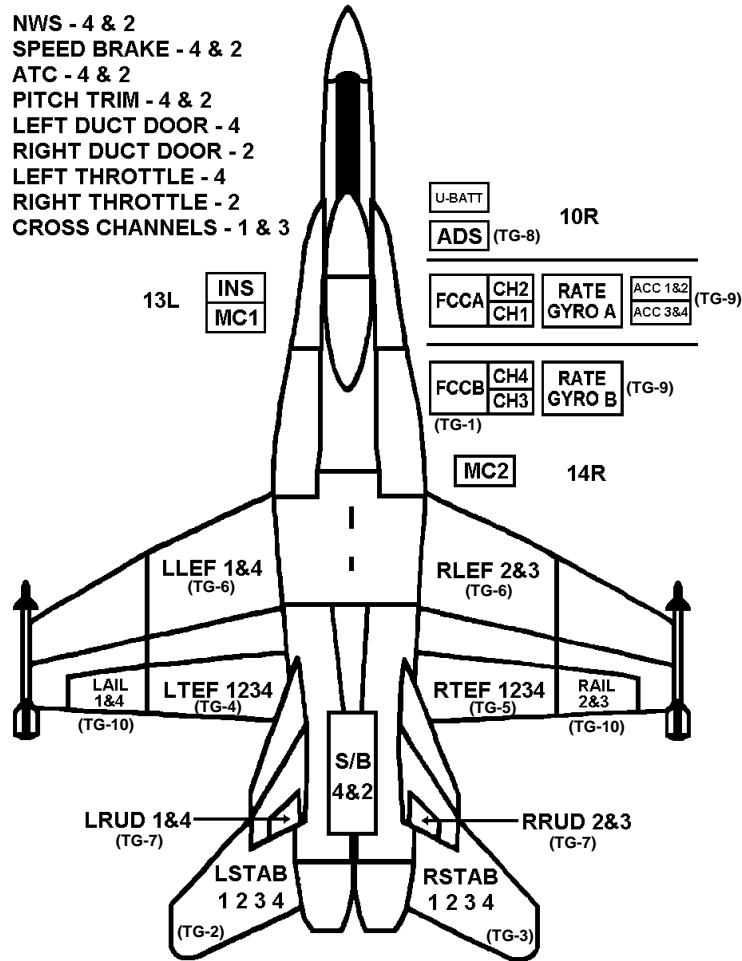

TSB™ v8.1.D.

FILE MODIFIED DATE - 6/15/05

(NOTE - IF THE FILE MODIFIED DATE DOES NOT MATCH FILE CREATED DATE, YOUR VERSION MAY BE MODIFIED AND NOT ACCURATE)

Point of Contact - Webmaster@MayPrinting.com

Look for updates at - <http://MayPrinting.com>

DESIGNED FOR BLUE 5 RING BINDER, 25 PAGES (NSN 7510-00-766-4269)

TO CUT PAGES TO 4-7/8" W x 7-7/8" L, FOLD 8-1/2" x 11" PAPER DOWN MIDDLE AND TRIM 5/8" FROM OPEN END AND BOTTOM EDGE

**Always Use Technical Publications for All
 Maintenance, this is ONLY a Quick Reference Aid.**

MAY III™ v8.1.D. - DATED 6/15/05 - PAGE 1

THIS MANUAL IS NOT WORD - THIS IS ONLY A QUICK REFERENCE - ALWAYS USE TECHNICAL PUBLICATIONS

AIRCRAFT TURN-UP CHECKLIST

- 1.) REVIEW AIRCRAFT STATUS AND SIGN TURN-UP LOGBOOK.
- 2.) BRIEF MAINTENANCE CONTROL AND ASSOCIATED WORK CENTERS.
- 3.) ENSURE A/C HAS REQUIRED TIEDOWNS AND CHOCKS INSTALLED.
- 4.) CLEAR AND TEST NWWDDI, PERFORM FLUIDS TEST ON NWWDDI.
- 5.) CHECK MMPs, IF MMP 988 APPEARS REPORT IMMEDIATELY.
- 6.) ENSURE A/C HAS A MINIMUM 2,000 LBS. OF FUEL.

WALK AROUND INSPECTION

- 1.) REMOVE LH/RH INTAKE COVERS.
- 2.) FOD CHECK AND INSPECT INLET DUCTS.
- 3.) INSTALL INTAKE SCREENS (NOT RECOMMENDED BELOW 0°C (32°F))
- 4.) REMOVE LH/RH INLET BLEED AIR EXIT DUCT AND DOOR PLUGS.
- 5.) REMOVE LH/RH RAM AIR INLET/OUTLET COVERS.
- 6.) REMOVE LH/RH ENGINE B-SUMP VENT PLUGS
- 7.) REMOVE LH/RH ENGINE BAY VENT COVERS.
- 8.) ENSURE ALL EXT FUEL TANK FILLER CAPS ARE INSTALLED PROPERLY.
- 9.) ENSURE GROUND SAFETY PINS (3 GEAR & 1 HOOK) ARE INSTALLED.
- 10.) ENSURE GROUNDING WIRE IS ATTACHED IN MLGWW (IF REQUIRED).
- 11.) INSPECT HYD1 & HYD2 LEVELS-56L/R.
- 12.) INSPECT HS-1 & HS-2 FILTER ΔP's L/R MLGWW.
- 13.) INSPECT ENG FUEL SOV'S ARE IN THE "OPEN" POSITION AND ELECTRICALLY CONNECTED IN L/R MLGWW.
- 14.) INSPECT APU THROUGH APU INTAKE SCREEN FOR FOLLOWING:
 - A.) FOD, OBSTRUCTIONS, AND LEAKS.
 - B.) APU OIL FILTER ΔP.
 - C.) APU SIGHT GLASS FOR PROPER SERVICING.
 - D.) APU FUEL FILTER ΔP.
- 15.) INSPECT AIR TURBINE STARTER (ATS) EXHAUST AREA FOR OBSTRUCTIONS.
- 16.) OPEN 54L/R AND INSPECT THE FOLLOWING:
 - A.) AMAD OIL FILTER ΔP.
 - B.) AMAD OIL LEVEL INDICATOR.
 - C.) AMAD AREA FOR LEAKS & FOD.
 - D.) POSITION DECOUPLE HANDLES IN REQ POSITIONS, CLOSE 54 LT.
- 17.) ENSURE 64L/R AND 68L/R ARE CLOSED OR SURFACE LOCKS ARE INSTALLED.
- 18.) OPEN 65L/R "LEAVE OPEN DURING TURN" AND INSPECT THE FOLLOWING:
 - A.) ENGINE AND VEN OIL FILTER ΔP's.
 - B.) ENGINE AND VEN OIL LEVEL INDICATORS FOR PROPER SERVICING.
 - C.) AREA FOR LEAKS AND FOD.
- 19.) INSPECT APU EXHAUST OUTLET.
- 20.) OPEN 69L/R AND INSPECT ENGINE FUEL FILTER ΔP's AND AREA FOR LEAKS, FOD, AND CLOSE 69L/R.
- 21.) REMOVE LH/RH TAILPIPE COVERS.
- 22.) INSPECT LH/RH AFTERBURNER DUCT, NOZZLE, AND TURBINE FOR DAMAGE.
- 23.) INSPECT APU ACCUMULATOR SERVICING IN RMLGWW.
- 24.) INSPECT EMER BRAKE ACCUMULATOR SERVICING (2900 PSI MIN) IN NLGWW.
- 25.) CONNECT INTERCOMMUNICATION EQUIPMENT (GROUND AND COCKPIT).
- 26.) ENSURE A/C HAS MINIMUM OF 2000 LBS. OF FUEL.
- 25.) STATION GUARD OBSERVER AND FIRE GUARD.
- 26.) SET CIRCUIT BREAKERS PER LMM-000.
- 27.) ENSURE CANOPY AND EJECTION SEAT SAFETY PINS ARE INSTALLED.

MAY III™ v8.1.D. - DATED 6/15/05 - PAGE 2

THIS MANUAL IS NOT WORD - THIS IS ONLY A QUICK REFERENCE - ALWAYS USE TECHNICAL PUBLICATIONS

COCKPIT SWITCHOLOGY

- 1.) MC AND HYD ISOL - NORM
- 2.) OXYGEN, OBOGS, AND OXY FLOW - OFF
- 3.) ANT SEL COMM - AUTO
- 4.) ANT SEL IFF - BOTH
- 5.) RADIO ORIDE/HOT MIC/COLD MIC - HOT MIC
- 6.) COMM RLY - OFF
- 7.) COMM G XMT - OFF
- 8.) ILS UFC/MAN - UFC
- 9.) IFF CRYPTO - NORM
- 10.) IFF MODE 4 - OFF
- 11.) IFF MASTER - NORM
- 12.) ICS VOL - AS REQUIRED
- 13.) APU AND ENGINE CRANK - OFF
- 14.) IFR PROBE - SAME AS PROBE POSITION
- 15.) EXT TANK: WING/CTR - NORM
- 16.) FUEL DUMP - OFF
- 17.) INT WING - NORM
- 18.) EXT LIGHTS: FORMATION - OFF, POSITION - MIDRANGE, STROBE - DIM
- 19.) LH/RH THROTTLES - OFF, FRICTION LEVER - AFT
- 20.) GND POWER - ALL SWITCHES - NORM/AUTO
- 21.) EMERG BRK/PARK BRK - PARK SET
- 22.) LAUNCH BAR - RETRACT
- 23.) FLAP- FULL
- 24.) SELECT JETT - SAFE
- 25.) LND/TAXI LIGHT - OFF
- 26.) ANTISKID - OFF (AFLOAT), ON (ASHORE)
- 27.) LDG GEAR CONTROL HANDLE - DOWN & WHITE TAB SHOWING
- 28.) MASTER SWITCH - SAFE
- 29.) LH/RH DDI - OFF
- 30.) LH/RH FIRE WARNING LIGHT - NOT PRESSED IN (NO BARBER POLE SHOWING)
- 31.) ADF - OFF
- 32.) COMM1 - AS REQUIRED
- 33.) HUD/HI/MCD - OFF
- 34.) AOA INDEXER - DIM
- 35.) DISPENSER AND ECM - OFF
- 36.) APU FIRE WARNING LIGHT - NOT PRESSED IN (NO BARBER POLE SHOWING)
- 37.) IR COOL - OFF
- 38.) ARRESTING HOOK CONTROL HANDLE - SAME AS HOOK POSITION
- 39.) WING FOLD CONTROL HANDLE - SAME AS WING POSITION
- 40.) FCS COOL - NORM
- 41.) LH/RH GENERATOR - NORM
- 42.) BATTERY - OFF
- 43.) ECS PANEL: ECS MODE - AUTO, SUIT/CABIN TEMP - MID RANGE, CABIN PRESS - NORM, BLEED AIR/ENG - NORM AND DOWN, PITOT - AUTO, ENG ANTI ICE - OFF (MUST BE ON, IF BELOW 7°C (45°F))
- 44.) INTERNAL LIGHTS - AS REQUIRED
- 45.) DEFOG - LEVER LOW
- 46.) WINDSHIELD ANTI-ICE/RAIN - OFF
- 47.) INS/RADAR/FLIR/LST/CAM/NFLR - OFF, LTD/R - SAFE
- 48.) KY-58 - OFF

APU START

- 1.) PERFORM: AIRCRAFT CHECKLIST, WALKAROUND, SWITCHOLOGY, AND ATAF
- 2.) BATT SWITCH - ON (ENSURE NO FIRE OR READY/DISCH LIGHTS COME ON)
- 3.) FIRE WARNING TEST - TEST A & TEST B (WAIT 5 SECONDS BETWEEN TESTS)
- 4.) COM1 - ON (VERIFY COMMUNICATIONS, AS REQUIRED)
- 5.) APU SWITCH - ON (READY LIGHT WITHIN 30 SECONDS)

APU FIRE LIGHT ILLUMINATED:

- 1.) APU FIRE LIGHT - PUSH
- 2.) FIRE EXTINGUISHER READY LIGHT - PUSH
- 3.) THROTTLES - OFF
- 4.) EGRESS (LEAVE BATTERY SWITCH ON).
- 5.) CONTACT GROUND/MAINTENANCE CONTROL, AS REQUIRED

ENGINE START

- 1.) ENGINE CRANK SWITCH - L or R (NEVER HOLD SWITCH)
- 2.) AT 15% N₂ RPM, MOVE THROTTLE TO IDLE (LIGHT-OFF WITHIN 20 SEC)
- 3.) VERIFY OIL PRESSURE IS 10 PSI WITHIN 30 SECONDS
- 4.) VERIFY ENGINE CRANK SWITCH OFF BY 61% N₂ AND L/R GEN LIGHTS OUT
- 5.) DDI's - ON
- 6.) VERIFY CAUTIONS AND ENGINE INDICATORS
- 7.) CYCLE BLEED AIR KNOB ONCE THRU TO NORM
- 8.) LIGHTS TEST
- 8.) FCS - RESET
- 9.) FLAPS - AUTO (SHUTDOWN IN FULL ONLY)

LH/RH ENGINE FIRE LIGHT ILLUMINATED:

- 1.) THROTTLES - OFF
- 2.) ILLUMINATED FIRE LIGHT - PUSH
- 3.) FIRE EXTINGUISHER READY LIGHT - PUSH
- 4.) BATTERY SWITCH - OFF
- 5.) EGRESS, CONTACT GROUND/MAINTENANCE CONTROL, AS REQUIRED

WARNING

IN THE EVENT OF AN APU/ENGINE FIRE, IMMEDIATELY NOTIFY GROUND/MAINTENANCE CONTROL OF THE SITUATION, AS REQUIRED, WITH THE FOLLOWING INFORMATION:

- 1.) AIRCRAFT SIDE/TAIL NUMBER
- 2.) LOCATION OF AIRCRAFT
- 3.) EMERGENCY SITUATION
- 4.) ASSISTANCE REQUESTED
- 5.) REPEAT ALL INFORMATION

NORMAL ENGINE INDICATIONS

AT IDLE	GE-400	GE-402
RPM	61-72% N ₂	63-70% N ₂
EGT	190-590°C	
FUEL FLOW	420-700 PPH	420-900 PPH
NOZZLE	73-84%	
OIL	45-110 PSI	
HYD PRESSURE	2850-3250 PSI	

EMERGENCY PROCEDURES

IF NO EGT RISE IN 20 SECONDS OR N₂ HUNG BELOW 61% (HUNG START):

- 1.) AFFECTED ENGINE THROTTLE - OFF
- 2.) CONTINUE CRANKING FOR 3 MINUTES
- 3.) THROTTLE - IDLE
- 4.) IF STILL NO START, ATTEMPT STEPS 1-3 ONE ADDITIONAL TIME AND SHUTDOWN IF ENGINE STILL FAILS

IF EGT CLIMBS RAPIDLY THRU 750°C (HOT START):

- 1.) AFFECTED ENGINE THROTTLE - OFF
- 2.) WINDMILL ENGINE UNTIL EGT IS BELOW 200°C
- 3.) IF 815°C NOT EXCEEDED THROTTLE - IDLE
- 4.) IF 815°C EXCEEDED OR ENGINE FAILS ON SECOND ATTEMPT, WINDMILL 3 MINUTES AND SHUTDOWN

INTERNAL ENGINE FIRE OR TAILPIPE FIRE (ENGINE/APU FIRE LIGHT NOT ILLUMINATED):

- 1.) AFFECTED ENGINE THROTTLE - OFF
- 2.) IF CONTINUES, PRESS AFFECTED ENGINE FIRE LIGHT
- 3.) ENSURE APU, EXTERNAL, OR CROSSBLEED AIR IS AVAILABLE
- 4.) WHEN AFFECTED ENGINE RPM DROPS BELOW 20% N₂ RPM, CRANK (WINDMILL) AFFECTED ENGINE FOR 5 MINUTES
- 5.) ENGINE CRANK SWITCH - OFF
- 6.) IF FIRE CONTINUES, DISCHARGE GROUND FIRE EXTINGUISHER INTO TAILPIPE
- 7.) EGRESS AND CONTACT GROUND/MAINTENANCE CONTROL, AS REQUIRED

RUNAWAY ENGINE/STUCK THROTTLE:

- 1.) PUSH LH/RH (AFFECTED) ENGINE FIRE LIGHT
- 2.) SHUTDOWN

FUEL LEAK/VENT:

- 1.) LH AND RH ENGINE FIRE LIGHTS - PUSH
- 2.) SHUTDOWN
- 3.) EGRESS, CONTAIN AND REPORT SPILL AS REQUIRED

L/R AMAD: LH/RH (AFFECTED) THROTTLE - OFF

L/R AMAD PRESS: LH/RH (AFFECTED) THROTTLE - OFF

L/R ATS (NON-GMM): LH/RH (AFFECTED) THROTTLE - OFF

AV AIR HOT:

- 1.) CYCLE BLEED AIR KNOB
- 2.) IF CAUTION REMAINS, ECS MODE SWITCH - MANUAL
- 3.) IF CAUTION REMAINS AFTER 1 MINUTE, ADVANCE EITHER THROTTLE TO 72% OR APPLY GROUND COOLING
- 4.) IF CAUTION REMAINS OR RETURNS, SHUTDOWN

LH/RH BLEED LIGHT ILLUMINATED:

- 1.) BLEED AIR SWITCH - OFF
- 2.) SHUTDOWN

L/R BLEED OFF:

- 1.) CYCLE BLEED AIR KNOB
- 2.) IF CAUTION REMAINS OR RETURNS, SHUTDOWN

L/R EGT:

- 1.) THROTTLES - IDLE
- 2.) IF CAUTION REMAINS, LH/RH THROTTLE - OFF

L/R ENG OIL PRESS:

- 1.) THROTTLE - IDLE
- 2.) IF CAUTION REMAINS, LH/RH THROTTLE - OFF

L/R ENG OVERSPEED: LH/RH (AFFECTED) THROTTLE - OFF

L/R FUEL HOT:

- 1.) INCREASE FUEL FLOW (ADVANCE EITHER THROTTLE TO 70%)
- 2.) WING FUEL SWITCH - NORM, MONITOR FUEL TEMP UNTIL <79°C
- 3.) IF CAUTION OR HIGH (>79°C) FUEL TEMP REMAINS OR RETURNS, SHUTDOWN

INLET ICE:

- 1.) ENGINE ANTI-ICE SWITCH - ON
- 2.) IF CAUTION REMAINS OR RETURNS, SHUTDOWN

WINDSHIELD HOT CAUTION:

- 1.) ANTI-ICE/RAIN REMOVAL SWITCH - OFF
- 2.) IF CAUTION REMAINS ON, BLEED AIR KNOB - OFF
- 3.) IF CAUTION REMAINS, SHUTDOWN

GROUND MAINTENANCE MODE (GMM)

(PROVIDES ELECTRICAL POWER AND ONE HYD SYSTEM)

- 1.) DECOUPLE L/R AMAD
- 2.) PERFORM APU START (ABOVE)
- 3.) ENGINE CRANK SWITCH - L or R (NEVER HOLD SWITCH)
- 4.) SWITCH STAYS ENGAGED, L/R GEN LIGHT OUT
- 5.) GROUND POWER 1, 2, AND 4 TO "B" ON
- 6.) DDI's - ON
- 7.) VERIFY CAUTIONS (LATS/RATS - SHOULD BE DISPLAYED ON GMM SIDE)
- 8.) LIGHTS TEST
- 9.) FCS - RESET
- 10.) FLAPS - AUTO (SHUTDOWN FULL ONLY)

ECS MODE

(PROVIDES ELECTRICAL AND ECS POWER, NO HYDRAULICS AVAILABLE)

- 1.) APPLY EXTERNAL ELECTRICAL POWER (NC-8, NC-10, WALL OR DECK)
- 2.) GROUND POWER 1 AND 2 TO "B" ON
- 3.) DDI's - ON
- 4.) PERFORM APU START (ABOVE)
- 5.) ECS AUG SWITCH - PULL
- 5.) VERIFY CAUTIONS
- 6.) LIGHTS TEST

GENERAL NOTES

- 1.) NEVER SHUTDOWN APU, WHEN CRANKING AN ENGINE OR WHEN ENGAGED IN GMM OR ECS MODE
- 2.) NEVER SHUTDOWN WITH FLAPS IN THE AUTO POSITION
- 3.) ON ENGINES FIRST START OF THE DAY OR IF INLET TEMP IS BELOW -18°C, OIL PRESS 2.5 MINUTES AFTER STARTUP MUST DROP BELOW 180 PSI
- 4.) ALL FLIGHT SURFACE MOVEMENTS SHALL BE COORDINATED WITH GROUND PERSONNEL

SETUP PROCEDURE FOR INS OPERATIONS

- 1.) RESET MMP CODES, HOOK UP SINS CABLE (IF REQUIRED)
- 2.) ENSURE PARKING BRAKE IS SET
- 3.) GROUND POWER 1 & 2 "B" ON
- 4.) ON DDI PRESS - HSI, DATA (REENTER IF INCORRECT), PRESS MENU, BIT, NAV
- 5.) GOTO APPLICABLE INS BIT OR ALIGNMENT BELOW

INS GROUND AND CV (RF/CBL) ALIGNMENT

- 1.) COMPLETE SETUP PROCEDURE ABOVE
- 2.) INS MODE SWITCH TO GND (SWITCH TO CV WITH SINS AVAILABLE ON SHIP)
- 3.) ON HSI DISPLAY - OBSERVE QUAL DIGITS COUNTING DOWN & TIME COUNTS UP, FLASHING TIME INDICATES ALIGNMENT HAS HALTED, SEE BELOW:
 - A.) ENSURE PARK BRAKE IS SET, CHECK MMPs (PULL INU WITH A 005 OR 115 MMP)
 - B.) **FOR CV ALIGNMENTS WITH FLASHING "RF"** - CHECK DATA LINK FREQUENCY (ON UFC), RUN DATA LINK BIT (IF DEGD, R&R DATA LINK), ENSURE SINS IS UP (LISTEN TO SINS FREQ ON COMM OR ASK ANOTHER AIRCRAFT), CONNECT SINS CABLE (IF STILL FLASHING "RF" OR "CBL": TRY ANOTHER SINS CABLE AND DECKWELL, CHECK PARK BRAKE SW BY PLACING INS SW TO GND, R&R DATA LINK (BIT GO DOES NOT MEAN D/L IS GOOD) OR TAKE A MANUALLY ALIGN IAW NFM-000), W/GPS AIRCRAFT - GO TO AINS IN-FLIGHT TO UPDATE THE MANUAL ALIGNMENT
 - C.) TURN INS TO "OFF" (WAIT 5 SEC (ASN-139), 3 MIN (ASN-130)) AND REATTEMPT ALIGNMENT
 - D.) TURN INS TO "OFF" (WAIT 5 SEC (ASN-139), 3 MIN (ASN-130)) AND R&R INU
- 4.) ALIGNMENT IS COMPLETE WHEN "OK" IS DISPLAYED AFTER QUAL#, TIME IS LESS THAN 4 MIN (ASN-139 GND), 5 MIN (ASN-139 CV), 10 MIN (ASN-130A)
- 5.) COMPLETE SHUTDOWN PROCEDURE BELOW

INS I-BIT

- 1.) COMPLETE SETUP PROCEDURE ABOVE
- 2.) INS MODE SWITCH TO TEST
- 3.) ON DDI - PRESS INS, WHEN PROMPTED PRESS GND (CV WITH SINS)
- 4.) BIT DISPLAY STATUS "GO" WITHIN 3 MIN (ASN-139), 12 MIN (ASN-130A)
- 5.) COMPLETE SHUTDOWN PROCEDURE BELOW

INS PLATFORM SLEW TEST

- 1.) COMPLETE SETUP PROCEDURE ABOVE
- 2.) INS MODE SWITCH TO TEST
- 3.) ON DDI - PRESS INS, PRESS "INS LONG", WHEN PROMPTED PRESS GND (CV WITH SINS)
- 4.) BIT DISPLAY STATUS "GO" WITHIN 45 MIN (ASN-139), 50 MIN (ASN-130A)
- 5.) COMPLETE SHUTDOWN PROCEDURE BELOW

INS GB CALIBRATION

- 1.) COMPLETE SETUP PROCEDURE ABOVE
- 2.) ON DDI - PRESS BIT, NAV, INS GB, GND GB (CV GB WITH SINS)
- 3.) INS MODE SWITCH TO GB, OBSERVE MODE WORD IS (040105)
- 4.) SHOULD REACH CALF=6 (COMPLETE) WITHIN 60 MINUTES (WAIT UNTIL CALF=6 TO CONTINUE)
- 5.) ON DDI - PRESS GB, RECORD 'I BIAS' VALUES FOR X, Y, AND Z
- 6.) NOTE: REPLACE INU IF CALF=6 GREATER THAN 70 MINUTES OR "X" OR "Y" BIAS < (± 0.0600) OR "Z" BIAS < (± 0.3000)
- 7.) COMPLETE SHUTDOWN PROCEDURE BELOW

SHUT DOWN PROCEDURE FOR INS OPERATIONS

- 1.) INS MODE SWITCH TO OFF, CHECK MMP CODES FOR 005 OR 115 (INS CODES)
- 2.) SHUTDOWN ALL ASSOCIATED EQUIPMENT (DDIs) AND REMOVE ELECTRICAL

FCS MAIN BIT

MANUAL SECTION

- 1.) FCS RESET
- 2.) TRIM SWITCH - NOSE UP 5 SEC, NOSE DOWN 5 SEC, RIGHT 5 SEC, LEFT 5 SEC
- 3.) PRESS AND RELEASE NWS SWITCH (VERIFY ENGAGE - HUD), THEN PRESS AND RELEASE NWS DISENGAGE (PADDLE) SWITCH (VERIFY DISENGAGE - HUD)
- 4.) EXTEND AND RETRACT LAUNCH BAR (VERIFY PROPER INDICATIONS)
- 5.) FLAPS SWITCH - FULL 5 SEC, HALF 5 SEC, AUTO 5 SEC, THEN HALF
- 6.) PRESS AND RELEASE ATC SWITCH
- 7.) SET SPIN SWITCH TO RCVY THEN BACK TO NORM
- 8.) UNLOCK WINGS THEN RELOCK (VERIFY PROPER INDICATIONS)
- 9.) FCS GAIN SWITCH TO OVERRIDE THEN BACK TO NORM, CHECK FOR BLIN CODES

AUTOMATED SECTION (TAKES APPROXIMATELY 78 SECONDS)

- 10.) PRESS FCS RESET, HALF FLAPS, TAKE-OFF TRIM SET (TRIM ADV DISPLAYED)
- 11.) MASTER CAUTION RESET
- 12.) ON DDI PRESS MENU, BIT, THEN MAINT AND/OR FCS (DEPENDING ON SOFTWARE)
- 13.) PRESS AND HOLD FCS MAINT & FCS BIT CONSENT SWITCH (UNTIL "IN TEST")
- 14.) ON "SW" MESSAGE - FLAP SWITCH TO AUTO
- 15.) ON "PNL" MESSAGE - RUDDER TRIM FULL RT, FULL LT, CENTER
- 16.) ON "STK" MESSAGE - STICK FWD TO STOP, STICK AFT TO STOP, NEUTRAL, STICK LEFT TO STOP, RIGHT TO STOP, NOSE TRIM FULL NOSE UP, FULL NOSE DOWN, TRIM MOMENTARILY RIGHT THEN LEFT
- 17.) ON "PED" MESSAGE - FULL RIGHT RUDDER, THEN FULL LEFT RUDDER
- 18.) IF "IN-TEST GO" IS DISPLAYED - END TEST (PRESS STOP, PADDLE SWITCH, RESET)
- 19.) IF "IN-TEST DEGD" IS DISPLAYED, READ BLIN AND MMP CODES AND TROUBLESHOOT

FCS TEST GROUPS

- 1.) IF USING GND POWER OR GMM - SET GND POWER SWITCHES 1, 2, AND 4 TO "B" ON
- 2.) ENSURE SPIN RECOVERY AND FCS GAIN SWITCHES ARE SET TO NORM
- 4.) PRESS FCS RESET, HALF FLAPS, TAKE-OFF TRIM SET (TRIM ADV DISPLAYED)
- 5.) ON DDI PRESS MENU, BIT, THEN MAINT AND/OR FCS (DEPENDING ON SOFTWARE)
- 6.) FCS OPTION (CYCLE UNTIL DESIRED TEST GROUP# APPEARS)
 - a.) **NWS BIT** (NEED SKID PLATES, ELECTRICAL, AND HYD-2 POWER ONLY)
 - b.) **FCS RIG**
 - c.) **ATC/PLC** (BOTH ENGINES & PROX BOX REQUIRED)
 - d.) **TG-1 TEST FCC'S** (NO HYD POWER REQUIRED)
 - e.) **TG-2 LEFT STAB**
 - f.) **TG-3 RIGHT STAB**
 - g.) **TG-4 LTEF**
 - h.) **TG-5 RTEF**
 - i.) **TG-6 LEF**
 - j.) **TG-7 RUDDERS** (ON "PNL" MESS - RRT, LRT, ON "PED" MESS - FRR, FLR)
 - k.) **TG-8 ADSU & ADS** (NO HYD POWER REQUIRED)
 - l.) **TG-9 LINEAR ACCELEROMETERS & RATE GYROS** (NO HYD POWER REQ)
 - m.) **TG-10AILERONS** (ON "STK" MESSAGE - STICK FULL LEFT & RIGHT)
 - n.) **TG-11 PITCH STICK** (ON "STK" MESSAGE - STICK FULL FWD & AFT)
 - o.) **TG-12 RATIO CHANGER** (ON "SW" MESSAGE - AUTO FLAPS, ON "STK" MESSAGE - NTFU, NTFD, TMR, TML)
- 7.) PRESS AND HOLD TG AND FCS BIT CONSENT SWITCH (UNTIL "IN TEST")
- 8.) IF "IN-TEST GO" IS DISPLAYED, PRESS STOP, PADDLE SWITCH, RESET
- 9.) IF "IN-TEST DEGD" IS DISPLAYED, READ BLIN AND MMP CODES AND T/S

ATC BIT

- 1.) PULL ALL PROBE HEATER "POWER" BREAKERS (NOT HEATER "CONTROL" BREAKERS)
- 2.) WITH PIN IN HOOK, ENSURE HOOK AREA IS CLEAR, SET HOOK HANDLE DOWN
- 3.) START BOTH ENGINES, EXT AND CTR TANKS TO STOP, PRESS FCS RESET, HALF FLAPS
- 4.) PROX BOX WEIGHT OFF WHEELS (LEFT MAIN ONLY), MEMORY INSPECT (14) 4516
- 5.) ADVANCE BOTH THROTTLES UNTIL MEMORY INSPECT IN CHANNELS 2&4 READ 024110-031653
- 6.) PRESS AND HOLD ATC AND FCS BIT CONSENT SWITCH (UNTIL "IN TEST")
ON "SW" MESSAGE - PRESS AND RELEASE ATC ENGAGE/DISENGAGE SWITCH
(THROTTLES WILL BOTH ADVANCE AND THEN RETARD ON THEIR OWN)
- 7.) ON "MECH" MESSAGE - APPLY 15 LBS. FORCE FORWARD AND AFT TO THROTTLE
- 8.) IF "IN-TEST GO" IS DISPLAYED, PRESS AND RELEASE ATC ENGAGE/DISENGAGE SWITCH, PRESS STOP, PADDLE SWITCH, RESET, REMOVE PROX BOX, SHUTDOWN
- 9.) IF "IN-TEST DEGD" IS DISPLAYED, READ BLIN AND MMP CODES AND T/S (WITH FAILURES - RUN TEST SEVERAL TIMES TO ENSURE DISCREPANCY IS VALID AND CONSISTENT)

FCS MEMORY INSPECT

(ALL BELOW READINGS ARE MEMORY INSPECTED WITH UNIT# 14)

ROLL STICK 4520	PITCH STICK 4517	RUDDER PEDAL 4521	RUDDER TRIM SW 4522
LEFT 077777 CENTER 000000 RIGHT 100000	AFT 060000 CENTER 000000 FWD 140000	LEFT 100000 CENTER 000000 RIGHT 077777	LEFT 077777 CENTER 000000 RIGHT 100000
NWS POS LOW GAIN (CH 2 & 4 ONLY) 4515	NWS POS HIGH GAIN (CH 2 & 4 ONLY) 4515	PLC POSITION (CH 2 & 4 ONLY) 4516	PLC FORCE (CH 2 & 4 ONLY) 4523
LEFT 163000 CENTER 000000 RIGHT 015400	LEFT 105500 CENTER 000000 RIGHT 076000	OFF 077777 IDLE 053000 A/B 103000	NO PRESS 000000 PRESSURE CYCLES
NWS SWITCH (CH 2 & 4 ONLY) 4650	PLC POSITION FAIL (CH 2 & 4 ONLY) 4651	PLC FORCE FAIL (CH 2 & 4 ONLY) 4651	ATC ENGAGE SWITCH (CH 2 & 4 ONLY) 4651
BIT 0 LOW	BIT 0 LOW	BIT 1 HIGH	BIT 3 LOW
PADDLE SWITCH 4661	RESET SWITCH 4661	BIT CONSENT SW 4672	SPIN RECOVERY SW 4660
BIT 14 HIGH	BIT 13 LOW	BIT 6 LOW	BIT 6 LOW
TAKE-OFF TRIM SW (CH 2 & 4 ONLY) 4650	WINGFOLD ENABLE AILERON STREAM-LINE SIGNAL (CH 2 & 4 ONLY) 4651	WINGFOLD LOCK PROX SWITCHES (CH 2 & 4 ONLY) 4651	SPEED BRAKE SWITCH (CH1&3 RETRACT, CH2&4 EXTEND) 4663
BIT 10 LOW	BIT 11 LOW	BIT 5 HIGH	BIT 15 HIGH
FLAP SWITCH 4660	FLAP SWITCH 4670	RATIO CHANGER 4651	BLEED AIR DOORS 3545
AUTO - BIT 3 LOW	HALF - BIT 5 LOW FULL - BIT 4 LOW	EXT - BIT 7 HIGH RET - BIT 0 HIGH	OPEN - BIT 3 HIGH CLOSE - BIT 1 HIGH

OCTAL TO BINARY CONVERSION CHART

BIT#	15	14	13	12	11	10	9	8	7	6	5	4	3	2	1	0
DATA																
BIT#	2, 5, 8, 11, 14			1, 4, 7, 10, 13			0, 3, 6, 9, 12, 15									
HIGH	4, 5, 6, 7			2, 3, 6, 7			1, 3, 5, 7									
LOW	0, 1, 2, 3			0, 1, 4, 5			0, 2, 4, 6									

EXAMPLE - PADDLE SWITCH READOUT FROM MEMORY INSPECT ADDRESS 4661 (UNIT 14) IS: 765432. FILL IN THE BLANK DATA BLOCKS OF THE UPPER CHART WITH: 765432. BIT 14 IS HIGH WHEN THE PADDLE SWITCH IS PRESSED. FROM THE UPPER CHART, NOTE THE DATA BLOCK FOR BIT 14 EQUALS 6. NOW USING THE LOWER CHART, NOTE THAT BIT# 14 IS IN THE 1ST COLUMN, NOW NOTE FROM THE 1ST COLUMN THAT A DATA VALUE OF 6 IS EQUAL TO BEING HIGH, THEREFORE, THE PADDLE SWITCH IS BEING PRESSED AT THE TIME THE MEMORY INSPECT WAS TAKEN.

FCS FAULT ISOLATION MEMORY INSPECT

(ALL BELOW READINGS ARE VALID WHEN MEMORY INSPECTED DURING RIG MODE WITH UNIT# 14)

STAB RAM POSITION		STAB CAS POSITION	
LEFT - 4530	RIGHT - 4532	LEFT - 4531	RIGHT - 4533
AUTO 073200 - 077777 HALF 000000 - 002400 FULL 177777 - 175000	073200 - 077777 000000 - 002400 177777 - 175000 000000 - 105000	FULL	000000 - 005700 177777 - 172100
LEFT FAIL 637	RIGHT FAIL 637	RIGHT FAIL 637	RIGHT FAIL 637
BIT 10 HIGH	BIT 12 HIGH	BIT 11 HIGH	BIT 13 HIGH
TEF RAM POSITION		TEF CAS POSITION	
LEFT - 4503	RIGHT - 4504	LEFT - 4510	RIGHT - 4512
AUTO 100000 - 104400 HALF 121200 - 126300 FULL 073300 - 077777	100000 - 104400 121200 - 126300 073300 - 077777	HALF	000000 - 001400 177777 - 176400
LEFT FAIL 3057	RIGHT FAIL 3057	LEFT FAIL 3057	LEFT FAIL 3057
BIT 0 HIGH	BIT 2 HIGH	BIT 1 HIGH	BIT 3 HIGH
LEF RAM POSITION (LEFT CH 1&4 - RIGHT CH 2&3)		LEF OTHER (LEFT CH 1&4 - RIGHT CH 2&3)	
INBOARD (HJU) - 4505		IN/OUTBOARD ASYMMETRY - 3310	
AUTO 112600 - 116200 HALF 123513 - 127125 FULL 064500 - 070100	112600 - 116200 123513 - 127125 064500 - 070100	IN ALL FLAP POSITIONS	000000 - 000700 177777 - 177100
OUTBOARD (ASSY CONTROL) - 4552		CAS POSITION - 4511	
AUTO 040200 - 043600 HALF 32600 - 03600 HALF (NOMINAL) 034261 FULL 132200 - 135600	040200 - 043600 32600 - 03600 034261 132200 - 135600	AUTO	000000 - 012300 177777 - 165500
RAM FAIL 4660		CAS FAIL 4661	
BIT 7 HIGH		BIT 5 HIGH	
RUDDER RAM POSITION (LEFT CH 1&4 - RIGHT CH 2&3) - 4526		RUDDER CAS POSITION 4527	
AUTO 046600 - 052500 HALF 000000 - 001700 FULL 177777 - 176000	046600 - 052500 000000 - 001700 177777 - 176000 125100 - 131000	FULL	000000 - 006300 177777 - 171500
RAM FAIL 4662	PEDAL FORCE FAIL 637	YAW TRIM FAIL 637	
BIT 15 HIGH	BIT 8 HIGH	BIT 9 HIGH	
AILERON RAM POSITION LEFT (CH 1&4) - 4524		AILERON CAS POSITION 4525	
AUTO 100000 - 107000 HALF 157100 - 164300 FULL 074000 - 077777	100000 - 107000 157100 - 164300 074000 - 077777	FULL	000000 - 003600 177777 - 174200
AILERON RAM POSITION LEFT (CH 2&3) - 4524		RAM FAIL 4661	ROLL STK FAIL 637
AUTO 071000 - 077777 HALF 013500 - 020700 FULL 100000 - 104000	071000 - 077777 013500 - 020700 100000 - 104000	BIT 15 HIGH	BIT 7 HIGH
		HYD PRESS ON 3073	
		BIT 8 HIGH	

FCS RESET/LAUNCH PROCEDURES

- 1.) **PRESS FCS RESET (IF WINGS ARE FOLDED, VERIFY AILERON X's ARE PRESENT, DO NOT PROCEED WITHOUT AILERONS X'ed OUT)**
 - a.) FLAPS TO HALF
 - b.) SET TAKE-OFF TRIM (VERIFY TRIM ADV IS DISPLAYED)
 - c.) PRESS FCS RESET AND REATTEMPT FCS PRE-FLIGHT BIT (FCS BIT)
 - d.) IF TEST IS "GO" - REPERFORM A FULL FCS WIPEOUT (PLANE CAPTAIN)
- 2.) **IF NO RESET OR FAILS TO GO INTO TEST (LEF NOT LOCKED-UP):**
 - a.) RUN ACTUATOR EXERCISER (SIMULTANEOUSLY PRESS AND RELEASE FCS BIT CONSENT AND FCS RESET BUTTONS)
 - b.) WHEN COMPLETE - PRESS PADDLE SWITCH, THEN RESET
 - c.) FLAPS TO HALF
 - d.) SET TAKE-OFF TRIM (VERIFY TRIM ADV IS DISPLAYED)
 - e.) PRESS FCS RESET AND REATTEMPT FCS PRE-FLIGHT BIT (FCS BIT)
 - f.) IF TEST IS "GO" - REPERFORM A FULL FCS WIPEOUT (PLANE CAPTAIN)
- 3.) **IF LEF IS LOCKED-UP (DO NOT RUN ACTUATOR EXERCISER):**
 - a.) PUT AIRCRAFT INTO FCS RIG MODE
 - b.) ALTERNATE BETWEEN THE PRESSING FCS RESET BUTTON AND CYCLING FLAP SWITCH THRU ALL POSITIONS, WAITING 5 SEC IN EACH POSITION. WHEN BOTH LEFs MOVE, FLAPS TO HALF, PRESS STOP
 - c.) SET TAKE-OFF TRIM (VERIFY TRIM ADV IS DISPLAYED)
 - d.) PRESS FCS RESET AND REATTEMPT FCS PRE-FLIGHT BIT (FCS BIT)
 - e.) IF TEST IS "GO" - REPERFORM A FULL FCS WIPEOUT (PLANE CAPTAIN)
- 3.) **IF STILL NO RESET OR STILL FAILS TO GO INTO TEST:**
 - a.) OPEN (PULL OUT) ALL FOUR FCS CIRCUIT BREAKERS IN COCKPIT
 - b.) WAIT 10 SECONDS
 - c.) RESET (PUSH IN) ALL FOUR FCS CIRCUIT BREAKERS IN COCKPIT
 - d.) PRESS FCS RESET BUTTON
 - e.) FLAPS TO AUTO
 - f.) PRESS FCS RESET BUTTON AND PADDLE SWITCH SIMULTANEOUSLY
 - g.) FLAPS TO HALF
 - h.) SET TAKE-OFF TRIM (VERIFY TRIM ADV IS DISPLAYED)
 - i.) PRESS FCS RESET AND REATTEMPT FCS PRE-FLIGHT BIT (FCS BIT)
 - j.) IF TEST IS "GO" - REPERFORM A FULL FCS WIPEOUT (PLANE CAPTAIN)
- 4.) **IF STILL PERSIST:**
 - a.) TROUBLESHOOT USING BLIN AND MMP CODES
 - b.) PERFORM A FCS TEST GROUP ON FCS SYSTEM FAILING
 - c.) IF FAILURE CAN NOT BE ISOLATED OR PRE-FLIGHT BIT (FCS BIT) FAILS TO COMPLETE TEST (WITH "IN-TEST GO"), THE AIRCRAFT IS DOWN
- 5.) **IF MAINT WAS PERFORMED, ALWAYS DO BELOW PRIOR TO FLIGHT:**
 - a.) FLAPS TO HALF
 - b.) SET TAKE-OFF TRIM (VERIFY TRIM ADV IS DISPLAYED)
 - c.) PRE-FLIGHT BIT (FCS BIT) - BIT STATUS "IN-TEST GO"
 - d.) PERFORM A FULL FCS WIPEOUT (PLANE CAPTAIN)
- 6.) **REMEMBER:**
 - a.) A FCS MAIN BIT IS REQUIRED WHEN SWAPPING OR CHANGING A FCC (570-300)
 - b.) AIRCRAFT CAN ONLY FLY WITH BLINS AUTHORIZED IN NFM-000

FCS CAUTION (WITH NO BLINS AND NO X's)

(IF BLIN CODES EXIST OR FCS MAIN BIT FAILS, TROUBLESHOOT IN ACCORDANCE WITH APPROPRIATE BLIN CODE)

- 1.) DO NOT PRESS "FCS RESET" UNTIL DATA IS RECORDED BELOW
- 2.) ON DDI - PRESS MENU, BIT, AND MI BUTTONS
- 3.) ON THE UFC - SELECT UNIT, ENTER 14 ON SCRATCH PAD, AND PRESS ENTER
- 4.) ON THE UFC - SELECT ADDR, ENTER 3266 SCRATCH PAD, AND PRESS ENTER
- 5.) RECORD THE EIGHT (8) DIGIT READOUT FOR EACH CHANNEL BELOW:

UNIT 14, ADDRESS 3266								
CH 1								
CH 2								
CH3								
CH4								

- 6.) ON DDI - PRESS THE UP ARROW TO INCREASE THE ADDR TO 3267.
- 7.) RECORD THE EIGHT (8) DIGIT READOUT FOR EACH CHANNEL BELOW:

UNIT 14, ADDRESS 3267								
CH 1								
CH 2								
CH3								
CH4								

- 8.) IF BOTH ADDRESS (3266 AND 3267) HAVE ALL ZEROS OR AIRCREW DID NOT PERFORM MEMORY INSPECT, THEN DATA HAS NOT BEEN CAPTURED PRIOR TO "FCS RESET", REPEAT PROCEDURE ON NEXT OCCURRENCE OR RUN PASS 1/2/3 DATA IF PROBLEM PERSISTS.
- 9.) IF EITHER ADDRESS (3266 OR 3267) CONTAINS DATA, COMPARE TO BELOW:

ADDRESS 3266 - REF 570-200, WP43, TBL7		
BIT 0 HIGH	XXXXX1	POWER ON RECOVERY HAS OCCURRED (PRESS FCS RESET) <small>- SINGLE CHANNEL - NORMALLY CAUSED BY CYCLING CIRCUIT BREAKERS, THE FCS CAUTION WILL NORMALLY CLEAR WITH FCS RESET. THIS IS NOT A FAILURE - ELSE CHANGE APPROPRIATE FCC</small>
BIT 1 HIGH	XXXXX2	PBIT TEST BYPASS OCCURRED
BIT 2 HIGH	XXXXX4	CROSS CHANNEL DATA LINK X-RECEIVER (FCC FAILURE) - (# - SEE BELOW)
BIT 3 HIGH	XXXX1X	CROSS CHANNEL DATA LINK Y-RECEIVER (FCC FAILURE) - (# - SEE BELOW)
BIT 4 HIGH	XXXX2X	CROSS CHANNEL DATA LINK Z-RECEIVER (FCC FAILURE) - (* AND # - SEE BELOW)
BIT 5-15	-	RESERVED

ADDRESS 3267 - REF 570-200, WP43, TBL7		
BIT 0-1	-	RESERVED
BIT 2 HIGH	XXXXX4	FCS AIR DAT CAUTION HAS OCCURRED (PITOT/STATIC FAILURE) <small>- REFER TO FC AIR DAT CAUTION PROCEDURE (FRM-000 WPS TBL27)</small>
BIT 3 HIGH	XXXX1X	R-LIM OFF CAUTION HAS OCCURRED (MC/SMS/GEN) <small>- REFER TO RANDOM FCS CAUTIONS PROCEDURE (FRM-000 WPS TBL27) OR INTERMITTENT DISPLAYS PROCEDURE (FRM-000, TBL3)</small>
BIT 4 HIGH	XXXX2X	NWS CAUTION OCCURRED - (# - SEE BELOW)
BIT 5 HIGH	XXXX4X	LEF STALL HAS OCCURRED (CH 1&4 - LEFT, CH 2&3 - RIGHT) <small>- PERFORM LEF STALL PROCEDURE (570-200 WP20 02 TBL7)</small>
BIT 6 HIGH	XXX1XX	FLAPS OFF CAUTION OCCURRED
BIT 7 HIGH	XXX2XX	RUDDER OFF CAUTION OCCURRED
BIT 8	-	RESERVED
BIT 9 HIGH	XX1XXX	AILERON OFF CAUTION OCCURRED
BIT 10 HIGH	XX2XXX	STABS OFF CAUTION OCCURRED
BIT 11 HIGH	XX4XXX	DEL ON CAUTION OCCURRED
BIT 12-15	-	RESERVED

* - IF ADDR 3266 AND 3267 BOTH SET XXXX2X, THIS IS NOT TWO FAILURES, IT INDICATES A SINGLE FAILURE OF THE CCDL Z-RECEIVER (# - SEE BELOW)
- ENSURE TO REPORT WHICH CCDL (I.E. CCDL X, Y, OR Z) FAILED ON TURN-IN MAF. TO ASSIST I-LEVEL (IATS (BENCH) MAY NOT DETECT THIS FAILURE)

F/A-18 HORNET MMP CODES

000	TEST VALUE	102	MPCD
000	TEST VALUE	103	AFT MPCD
001	ADC TERMINAL	104	RWR CONTROL INDICATOR (CSU)
002	LDDI TERMINAL	105	RWR QUAD RECEIVER L FWD - 315°
003	RDDI TERMINAL	106	RWR QUAD RECEIVER L AFT - 225°
004	CSC (CONTROL CONVERTER) TERMINAL	107	RWR QUAD RECEIVER R AFT - 135°
005	INS TERMINAL	108	RWR QUAD RECEIVER R FWD - 45°
006	SMS (ARMAMENT COMPUTER) TERMINAL	109	RWR INTEGRATED ANTENNA
007	FLIR TERMINAL	10A	INTG ANTENNA DETECTOR - 315°
008	DSS/AMU/MU (FIRAMS) TERMINAL	10C	INTEGRATED ANTENNA DETECTOR - 225°
009	NAVFLIR TERMINAL	10E	INTEGRATED ANTENNA DETECTOR - 135°
010	RADAR TERMINAL	10F	INTEGRATED ANTENNA DETECTOR - 45°
011	CIT (IFF) TERMINAL	110	RWR SPECIAL RECEIVER
012	LST/SCAM TERMINAL	111	ALR-67 COMPUTER
013	ASPJ (JAMMER) TERMINAL	112	DMC (MAP COMPUTER)
014	FCCA TERMINAL	113	DMU (MEMORY UNIT)
015	FCCB TERMINAL	114	VIDEO RELAY PANEL
016	DATA LINK TERMINAL	115	INS
017	HARM CLC TERMINAL	116	INS SHUTDOWN
018	COMM1 TERMINAL	11A	DMS SOFTWARE CONFIG INCOMPATIBLE
019	COMM2 TERMINAL	11C	EW MUX/ALE-47 INTERFACE/TERMINAL FAIL
020	RWR/COUNTERMEASURES TERMINAL	125	ADC
021	MMLS OR VOR/LS RECEIVER TERMINAL	126	R AOA (ADSU) SENSOR
022	COMM 3/HF COMM TERMINAL	127	L AOA (ADSU) SENSOR
023	ATARS (RECCE SYS) TERMINAL	129	TOTAL TEMP SENSOR
024	TACTS/AISI TERMINAL	12A	EW MUX/IBU-INTERFACE/TERMINAL FAIL
025	SDS/ALE-47 TERMINAL	12C	EW MUX/JAMMER FAIL
026	DFIRS TERMINAL	12E	EW MUX/HARM-INTERFACE/TERMINAL FAIL
027	DMS (DIGITAL MAP) TERMINAL	130	S/B ALTIMETER BARO SET
029	MC2 TERMINAL	131	MAD
02A	EGI - INS TERMINAL	132	MAD COMPENSATOR PANEL
02C	EGI - GPS TERMINAL	133	AOA EQUALITY
02E	MIDS TERMINAL	134	ADC IBT DELTA P
02F	EGI DATA FREEZE	140	MMLS NAV COMPUTER
030	SDC (MSDRS REC/FIRAMS) TERMINAL	141	MMLS RADIO RECEIVER
031	EGI WRA FAIL	142	MMLS DIRECTIONAL COUPLER
032	MC 1 (REPLACE)	145	CONTROL CONVERTER
034	MC 1 MEMORY (RELOAD)	146	ICS/AC
036	MC 2 (REPLACE)	147	RADAR ALTIMETER R/T
037	MC 2 MEMORY (RELOAD)	148	LS
038	MC 1 WARM START FAIL	149	INTERFERENCE BLANKER
039	MC 2 WARM START FAIL	150	IFF
040	RADAR TARGET DATA PROCESSOR	151	RADAR (BEACON) RECEIVER
041	RADAR TRANSMITTER	152	TACAN
042	RADAR RECEIVER EXCITER	153	RADAR (BEACON) TRANSMITTER
043	RADAR COMPUTER POWER SUPPLY	154	M4 Z WRA
044	RADAR ANTENNA	155	FIRAMS/SDC
045	RADAR ANTENNA SERVO GIMBAL	157	IFEI FWD
046	RADAR COOLANT FLOW LOW	158	IFEI AFT
047	RADAR WAVEGUIDE PRESSURE LOW	159	MU (MEMORY UNIT)
048	RADAR SYS WOW/INFLIGHT DISAGREE	15A	MAINTENANCE PC CARD FAIL
052	RUN RADAR 1-BIT	15C	MISSION PC CARD FAIL
062	GPS TERMINAL	15E	AMU/PC CARD FAIL
063	GPS RECEIVER	15F	AMU/DMS/HSIB FAIL
064	GPS BATTERY	160	MU TO MC DATA TRANSFER
065	GPS KEY PARITY ERROR	161	FIRAMS INSTALLED DISCRETE
066	GPS KEY INCORRECT	162	MAINT DATA ON MU
067	GPS KEY NOT LOADED	163	MDRM NOT INSTALLED
068	RADAR SYS LAUNCH INIT	164	VOR/LS RECEIVER
069	RADAR EMERGENCY MODE SELECTED	165	SDRS
070	SMS (ARMAMENT) COMPUTER	166	MDRM
071	STATION 1 DECODER	167	MSDC
072	STATION 2 DECODER	168	NW/WDI OR DC BRIDGE FAIL
073	STATION 3 DECODER	169	STRAIN GAUGE DC BRIDGE
074	STATION 4 DECODER	171	HF COMM R/T
076	STATION 6 DECODER	172	HF COMM COUPLER
077	STATION 7 DECODER	173	HF COMM ANTENNA
078	STATION 8 DECODER	174	HF COMM PRESSURE LOW
079	STATION 9 DECODER	175	COMM 1
080	GUN DECODER	176	COMM 1 EXCESSIVE VSWR
081	FUZZING (AWW-4) POWER SUPPLY	177	COMM 2
082	EMERGENCY-JETT SELECTED	178	COMM 2 EXCESSIVE VSWR
083	SELECT-JETT SELECTED	179	DATA LINK
084	TRIGGER SWITCH ACTIVATED	180	DATA LINK EXCESSIVE VSWR
085	BOOMB RELEASE ACTIVATED	181	COMM 3
086	TACTS (AISI)	182	COMM 3 EXCESSIVE VSWR
095	LDDI	185	FCCA
096	RDDI	186	FCCB
097	HI	187	ACCELEROMETER A
098	HUD	188	ACCELEROMETER B
099	AFT LDDI	189	AFT LDDI
0A0	EU FAIL	190	RATE GYRO A
0A1	HELMET MOUNT INDICATOR FAIL	191	RATE GYRO B
0A2	HELMET MAG TRACKER FAIL	192	CONTROL STICK POSITION SENSORS
0A3	HELMET COCKPIT UNIT FAIL	193	RUDDER CONTROL
0A4	FWD SEAT POSITION SENSOR FAIL	194	FCS CONTROL PANEL
0A5	FWD CONTROL PANEL FAIL	195	READ BIT CODE
0A6	FWD AMBIGUOUS FAIL	201	FCS CABLE - FCS PNL TO FCCA
0A7	AFT CONTROL PANEL FAIL	202	FCS CABLE - FCS PNL TO FCCB
0A8	AFT AMBIGUOUS FAIL	203	FCS CABLE - STK GRIP TO FCCA/B
0A9	TERMINAL FAIL	204	FCS CABLE - STK SENSORS TO FCCA/B
0AA	AFT HMD FAIL	205	FCS CABLE - RUD SENSOR TO FCCA/B
0AC	AFT MAGNETIC TRACKER FAIL	206	FCS CABLE - RUD SENSOR TO FCCA/B
0AE	AFT COCKPIT UNIT FAIL	207	FCS CABLE - AFT RUD SENSOR TO FCCA/B
0AF	AFT SEAT POSITION SENSOR FAIL	208	FCS CABLE - AFT RUD SENSOR TO FCCA/B
100	AFT RDDI	209	FCS CABLE - ADS TO FCCA
101	AFT HI	210	FCS CABLE - ADS TO FCCB

MAY III™ v8.1.D. - DATED 6/15/05 - PAGE 13

THIS MANUAL IS NOT WORD - THIS IS ONLY A QUICK REFERENCE - ALWAYS USE TECHNICAL PUBLICATIONS

F/A-18 HORNET MMP CODES

211	FCS CABLE - ACCEL TO FCCA	30E	LASER ELECTRONICS UNIT (LEU)
212	FCS CABLE - ACCEL TO FCCB	30F	ENVIRONMENTAL CONTROL VALVE (EVC)
213	FCS CABLE - GYRO TO FCCA	310	FLIR L HEAT BLOWER
214	FCS CABLE - GYRO TO FCCB	311	FLIR R HEAT BLOWER
215	FCS CABLE - NWS PWR UNIT TO FCCA/B	312	FLIR POD FWD SECTION FAN
216	FCS CABLE - FCCA TO FCCB	313	LDT TRANSMITTER
218	RUN NWS BIT	314	LDT POWER SUPPLY
219	RUN ATC BIT	315	RESERVED - TARGET PROCESSOR
222	RUN TG-2 (L STAB)	316	FLIR CHECKSUM (CONTROLLER PROC)
223	RUN TG-3 (R STAB)	317	DFIRS DATA ON MU
224	RUN TG-4 (L TEF)	318	DFIRS/MEMORY UNIT TRANSFER
225	RUN TG-5 (R TEF)	319	DFIRS BEACON
226	RUN TG-6 (LEF)	31A	NAVFLIR SENSOR UNIT (NFS)
227	RUN TG-7 (RUD)	31C	ENERGY STORAGE UNIT (ESU)
228	RUN TG-8 (ADS)	31E	DIGITAL NONUNIFORMITY CORRECTION (DNUC)
230	RUN TG-10 (AIL)	31F	DIGITAL PROCESSOR 1 (SP1)
231	RUN TG-11 (STK/NWS/ATC)	320	DFIRS MEMORY TEST
234	COMM 1 (ARC-210) PBIT	321	DFIRS SDR
235	COMM 1 (ARC-210) APPLIQUE	322	DFIRS DATA TRANSFER INTERFACE UNIT
236	COMM 1 (ARC-210) RT	325	LDT DETECTOR
237	COMM 1 (ARC-210) EXCESSIVE VSWR	326	LDT INTERCONNECT BOX
238	COMM 2 (ARC-210)DCS) PBIT	327	NVFLIR IR
239	COMM 2 (ARC-210) APPLIQUE	328	NVFLIR COMPUTER CONVERTER
23A	DCS BATTERY LOW	329	NVFLIR THERMAL CONTROL
240	COMM 2 (ARC-210)DCS) RT	32A	SIGNAL PROCESSOR 2 (SP2)
241	COMM 2 (ARC-210)DCS) EXCESSIVE VSWR	32C	SERVO INTERFACE (SIM)
242	COMM 1 NRAM WRITES EXCEEDED	32E	SERVO CONTROLLER (SC)
243	COMM 1 WRA FAIL	32F	VIDEO PROCESSOR (SC)
244	COMM 2 NRAM WRITES EXCEEDED	330	DLEC TERMINAL
245	COMM 2 WRA FAIL	331	DLEC WRA FAIL
246	COMM 1 ECCM BATTERY	332	DLEC TO COMM 1 INTERFACE
247	COMM 2 ECCM BATTERY	333	DLEC TO COMM 2 INTERFACE
248	D/L TERMINAL	334	IFF (APX-111) IT WRA
249	D/L WRA FAIL	335	IFF (APX-111) CRYPTO OR CRYPTO WRA FAIL
24A	MIDS FAIL - MAIN TERM OR REMOTE PWR SUPPLY	336	IFF UPPER BFN
24C	MIDS PWR SUPPLY FAIL (RPS OR IPS)	337	IFF LOWER BFN
24F	RUN MIDS IBIT	338	UPPER TRANSPONDER ANTENNA/CH
250	LAEO IU (RECCE)	339	LOWER TRANSPONDER ANTENNA/CH
251	LAEO MEU (RECCE)	33A	POD CAMERA DRIVE (C)
252	MAEO IU (RECCE)	33C	SCENE-BASED NONUNIFORMITY CORRECTION
253	MAEO MEU (RECCE)	33E	CONTROL AND INTERFACE MODULE (CIM)
254	MAEO CEU (RECCE)	33F	POWER SUPPLY EMI MODULE (PSEMI)
255	MAEO RATE GYRO (RECCE)	340	CIT CRYPTO BATTERY LOW
256	IRLS RECEIVER (RECCE)	341	TEST VALUE
257	IRLS SEU (RECCE)	343	FIBER OPTIC LINK FAIL
258	DTR1 RRU (RECCE)	34A	POWER SUPPLY DIGITAL MODULE (PSD)
259	DTR1 TTU (RECCE)	34C	POWER SUPPLY ANALOG MODULE (PAD)
25A	MIDS LOWER NOTCH FILTER FAIL	34E	POWER SUPPLY DIGITAL +3.3V MODULE (PS3.3)
260	DTR2 RRU (RECCE)	34F	POWER SUPPLY CONTROL/BIT MODULE (PSCB)
261	DTR2 TTU (RECCE)	350	STRIKE CAMERA FAIL
262	D/L AMA (RECCE)	351	STRIKE CAMERA DRIVE MOUNT FAIL
263	D/L RFA (RECCE)	352	ALE-47 PROGRAMMER
264	D/L ANTENNA (RECCE)	353	ALE-47 RIGHT SEQUENCER
265	D/L COMSEC (RECCE)	354	ALE-47 LEFT SEQUENCER
266	D/L CABLE (RECCE)	355	ALE-47 LEFT REAR DISPENSER
267	D/L AMA/ANT/POWER RELAY AMBIGUITY	356	ALE-47 LEFT FWD DISPENSER
268	RECCE MANAGEMENT SET (RMS)	357	ALE-47 RIGHT REAR DISPENSER
269	VERTICAL REFERENCE GYRO (RECCE)	358	ALE-47 LEFT REAR DISPENSER
270	LAEO IU PM (RECCE)	359	ALE-47 MISFIRE
271	LAEO MEU PM (RECCE)	35A	WRA-21 - NOT USED
272	MAEO IU PM (RECCE)	35C	POD ELECTRICAL HOUSING (PEH)
273	MAEO MEU PM (RECCE)	35E	ROLL DRIVE UNIT (RDU)
274	MAEO CEU PM (RECCE)	35F	ROLL DRIVE AMPLIFIER (RDA)
275	MAEO RATE GYRO (RECCE)	362	ALQ-126B (ECM)
276	IRLS RECEIVER PM (RECCE)	363	ALQ-162
277	IRLS SEU PM (RECCE)	364	INTERROGATOR ANTENNA 1
278	DTR1 RRU PM (RECCE)	365	INTERROGATOR ANTENNA 2
279	DTR1 TTU PM (RECCE)	366	INTERROGATOR ANTENNA 3
280	DTR2 RRU PM (RECCE)	367	INTERROGATOR ANTENNA 4
281	DTR2 TTU PM (RECCE)	368	INTERROGATOR ANTENNA 5
282	D/L AMA PM (RECCE)	369	INTERROGATOR ANTENNA 6
283	D/L RFA PM (RECCE)	36A	ROLL DRIVE MOTOR (RDM)
284	D/L ANTENNA PM (RECCE)	36C	POD ADAPTER (PAU)
285	D/L COMSEC PM (RECCE)	370	INTERROGATOR ANTENNA 7
286	D/L CABLE PM (RECCE)	371	INTERROGATOR ANTENNA 8
288	RMS PM (RECCE)	372	INTERROGATOR ANTENNA 9
289	LAEO MUX (RECCE)	373	INTERROGATOR ANTENNA 10
290	MAEO MUX (RECCE)	375	CLC/HARM
291	IRLS MUX (RECCE)	376	CLC/SMS INTERFACE
292	D/L MUX (RECCE)	377	CLC/RWR (ALR-67) INTERFACE
293	DTR1 MUX (RECCE)	378	HARM STATION 2
294	DTR2 MUX (RECCE)	379	HARM STATION 3
295	DTR1 TAPE INSTALLATION ERROR	380	HARM STATION 7
296	DTR2 TAPE INSTALLATION ERROR	381	HARM STATION 8
2A0	EGI CEP TEST FAIL	382	HARM INTERFACE STATION 2
300	FLIR OPTICS STABILIZER	383	HARM INTERFACE STATION 3
301	FLIR POD FWD SECTION	384	HARM INTERFACE STATION 7
302	FLIR ROLL DRIVE AMP	385	HARM INTERFACE STATION 8
303	FLIR ROLL MOTOR	389	RADAR DATA LINK NOT INSTALLED
304	FLIR POWER SUPPLY	38A	AMBIGUITY 1
305	FLIR CONTROLLER PROCESSOR	38C	AMBIGUITY 2
306	FLIR SERVO CONTROLLER	38E	AMBIGUITY 3
307	FLIR POD FWD SECTION	38F	AMBIGUITY 4
308	FLIR TEMP CONTROL	390	WEAPON STATION 1
309	FLIR POD AFT SECTION	391	WEAPON STATION 2 LEFT
30A	EOU ASSEMBLY FAIL	392	WEAPON STATION 2 RIGHT
30C	LASER TRANSCIEVER FAIL	393	WEAPON STATION 3 LEFT

MAY III™ v8.1.D. - DATED 6/15/05 - PAGE 14

THIS MANUAL IS NOT WORD - THIS IS ONLY A QUICK REFERENCE - ALWAYS USE TECHNICAL PUBLICATIONS

F/A-18 HORNET MMP CODES

394	WEAPON STATION 3 RIGHT	495	EXT TANKS FAILED TO PRESSURIZE
395	WEAPON STATION 4 LEFT	496	EXT TANKS FAILED TO VENT
396	WEAPON STATION 4 RIGHT	497	INTERNAL PRESSURE REGULATOR
397	WEAPON STATION 5 LEFT	498	FUEL DUMP VALVE
398	WEAPON STATION 5 RIGHT	499	L DIVERTER VALVE
399	WEAPON STATION 6 LEFT	500	R DIVERTER VALVE
39A	AMBIGUITY 5	501	REDISTRIBUTION VALVE
39C	AMBIGUITY 6	502	TANK 2 LEVEL SENSOR
39E	AMBIGUITY 7	503	TANK 3 LEVEL SENSOR
39F	AMBIGUITY 8	504	LEFT SCAVENGE TANK
400	WEAPON STATION 6 RIGHT	505	RIGHT SCAVENGE TANK
401	WEAPON STATION 7 LEFT	506	TANK 3 LOW THERMISTOR
402	WEAPON STATION 7 RIGHT	507	TANK 2 LOW THERMISTOR
403	WEAPON STATION 8 LEFT	508	EXT TANK 5 PSI PRESSURE SWITCH
404	WEAPON STATION 8 RIGHT	509	EXT TANK 34 PSI PRESSURE SWITCH
405	WEAPON STATION 9	510	INT TANK 2 PSI PRESSURE SWITCH
409	ASPJ (ALQ-165) CBIT FAIL	511	VENT TANK WET
40C	FWD RF-PREAMPLIFIER FAIL	517	IFR PROBE CONTROL/POSITION
40E	AFT RF-PREAMPLIFIER FAIL	518	FUEL QUANTITY/LOW LEVEL DISAGREE
40F	ASPJ RF TUNABLE FILTER/COUPLER FAIL	531	TANK 1 FWD FUEL PROBE
410	ASPJ LOW BAND RECEIVER	532	TANK 1 AFT FUEL PROBE
411	ASPJ HIGH BAND RECEIVER	533	TANK 2 PROBE
412	ASPJ PROCESSOR	534	TANK 3 PROBE
413	ASPJ LOW BAND TRANSMITTER	535	TANK 4 FWD PROBE
414	ASPJ HIGH BAND TRANSMITTER	536	TANK 4 CENTER PROBE
415	MC1 DISCRETE	537	TANK 4 AFT PROBE
416	MC2 DISCRETE	538	L WING INBOARD PROBE
417	R CONTROLLER DISCRETE	539	R WING CENTER PROBE
418	L CONTROLLER DISCRETE	540	L WING OUTBOARD PROBE
419	MC1 INSTALLATION ERROR	541	R WING INBOARD PROBE
420	INSTALL MAG TAPE	542	R WING CENTER PROBE
421	HI ON LAST LAMP (NO SPARES)	543	R WING OUTBOARD PROBE
423	HARDWARE EQUIP DISCRETE MISMATCH	544	CENTERLINE EXT TANK PROBE
424	AIRCRAFT CONFIGURATION DISCRETE	545	R EXT TANK PROBE
425	RECCE DOOR DISCRETE FROM CSC	546	R EXT TANK PROBE
426	RECCE DOOR DISCRETE FROM FCS	549	VENT TANK WET SENSOR
427	ADC SOURCE CORRECTION INCORRECT	550	L BOOST INLET TRANSDUCER
428	MC1 VPM UPGRADE	551	R BOOST INLET TRANSDUCER
429	MC2 VPM UPGRADE	552	FUSE TRANSFER TRANSDUCER
430	MC1 NOT 6TH MUX BUS COMPATIBLE	553	VENT TANK PRESSURE TRANSDUCER
431	MC2 NOT 6TH MUX BUS COMPATIBLE	554	TANK 1 MOTIVE FLOW TRANSDUCER
432	MC 6TH MUX BUS MISMATCH	555	TANK 4 MOTIVE FLOW TRANSDUCER
440	FUEL CROSSFEED SOV	556	RESERVED - DC BRIDGE 7
441	L ENG FUEL SOV	557	EXT AIR PRESSURE TRANSDUCER
442	L BOOST PRESSURE SWITCH	558	L WING MOTIVE FLOW TRANSDUCER
443	TANK 2 INTERCONNECT VALVE	559	R WING MOTIVE FLOW TRANSDUCER
444	TANK 2 TURBINE BOOST PUMP	561	TANK 2 LEVEL SENSOR TRANSDUCER
445	L MOTIVE FLOW/BOOST PUMP	562	TANK 3 LEVEL SENSOR TRANSDUCER
446	L OR #2 MOTIVE FLOW/BOOST PUMP	563	RESERVED - DC BRIDGE 11
447	R ENG FUEL SOV	564	TANK 1 REFUEL SOV
448	R BOOST PRESSURE SWITCH	565	TANK 2 REFUEL SOV
449	TANK 3 INTERCONNECT VALVE	566	TANK 3 REFUEL SOV
450	TANK 3 TURBINE BOOST PUMP	567	TANK 4 REFUEL SOV
451	R MOTIVE FLOW/BOOSTPUMP	568	L WING REFUEL SOV
452	R OR #3 MOTIVE FLOW/BOOST PUMP	569	R WING REFUEL SOV
453	TANK 1 FAIL TO CLOSE	570	L EXT TANK REFUEL SOV
454	TANK 1 INTERCONNECT VALVE	571	CENTERLINE TANK REFUEL SOV
455	TANK 1 INTERCONNECT SOV	572	R EXT TANK REFUEL SOV
456	TANK 1 AMBIGUITY	573	TANK 1 REFUEL HI PILOT SOV
457	CROSSMOTIVE VALVE	574	TANK 2 REFUEL HI PILOT SOV
458	L WING TRANSFER JET EJECTOR PUMP	575	TANK 3 REFUEL HI PILOT SOV
459	L WING MOTIVE FLOW GROUP 1	576	TANK 4 REFUEL HI PILOT SOV
460	L WING MOTIVE FLOW GROUP 2	577	L WING REFUEL HI PILOT SOV
461	R WING TRANSFER JET EJECTOR PUMP	578	R WING REFUEL HI PILOT SOV
462	R WING MOTIVE FLOW GROUP 1	579	L EXT TANK HI PILOT SOV
463	R WING MOTIVE FLOW GROUP 2	580	CENTERLINE TANK HI PILOT SOV
464	TANK 1 TRANSFER CONTROL VALVE	581	R EXT TANK HI PILOT SOV
465	TANK 1 TRANSFER SOV	582	FUEL QUANTITY
466	TANK 1 TRANS LOW LEVEL PILOT VALVE	583	FUEL LOW, REFUEL AND RETEST
467	TANK 1 TRANSFER CONTROL VALVE	584	FUEL SPILL IMMINENT
468	TANK 1 TRANS LOW LEVEL PILOT VALVE	585	TRANSFER SOV
469	TANK 1 MOTIVE FLOW SYSTEM	586	TANK/TANKS FULL
470	L MOTIVE FLOW SYSTEM RESTRICTED	587	AMBIGUOUS RESULTS (REFUEL SYS)
471	TANK 4 TRANSFER CONTROL VALVE	588	NO FAILURE FOUND (REFUEL SYS)
472	TANK 4 TRANSFER SOV	589	IRW3LD RPM
473	TANK 4 TRANSFER LOW LEVEL PILOT	590	R FUEL BOOST PUMP PRESS PUMP/SWITCH
474	TANK 4 TRANSFER CONTROL VALVE	591	L FUEL BOOST PUMP PRESS PUMP/SWITCH
475	TANK 4 TRANS LOW LEVEL PILOT VALVE	600	WINGFOLD STRAIN GAUGE (& MMP 926)
476	TANK 4 MOTIVE FLOW SYSTEM	601	DRAG BRACE STRAIN GAUGE (& MMP 926)
477	R MOTIVE FLOW SYSTEM RESTRICTED	602	L STAB STRAIN GAUGE (& MMP 926)
478	TANK 2 TRANSFER SOV FAILED OPEN	603	R STAB STRAIN GAUGE (& MMP 926)
479	TANK 2 TRANSFER SOV FAILED CLOSED	604	L VERTICAL STRAIN GAUGE (& MMP 926)
480	TANK 3 TRANSFER SOV FAILED OPEN	605	R VERTICAL STRAIN GAUGE (& MMP 926)
481	TANK 3 TRANSFER SOV FAILED CLOSED	606	L WING ROOT STRAIN GAUGE (& MMP 926)
482	FEED TANK TRANSFER	650	L ENG FAN SPEED
483	TANK 1 PUMP	651	L ENG COMPRESSOR SPEED
484	MANIFOLD LEAK	652	L ENG EGT
485	TANK 4 PUMP	656	L ENG FAN VIBRATION HIGH
486	TANK 1 TRANSFER PUMP/MANIFOLD	657	RESERVED - L ENG FUEL FLOW
487	TANK 4 TRANSFER PUMP/MANIFOLD	658	L FUEL TEMP
488	L WING EXT TANK TRANSFER	659	L ENG COMPRESSOR DISC PRESSURE
489	R WING EXT TANK TRANSFER	660	L ENG TURBINE DISC PRESSURE
490	CENTERLINE EXT TANK TRANSFER	661	L ENG INLET TEMP
491	TANK 1 LC FAIL TO CLOSE	662	L ENG OIL PRESSURE
492	TANK 4 LC FAIL TO CLOSE	666	R ENG FAN SPEED
493	L WING LCV FAIL TOP CLOSE	667	R ENG COMPRESSOR SPEED
494	R WING LCV FAIL TO CLOSE	668	R ENG EGT

MAY III™ v8.1.D. - DATED 6/15/05 - PAGE 15

THIS MANUAL IS NOT WORD - THIS IS ONLY A QUICK REFERENCE - ALWAYS USE TECHNICAL PUBLICATIONS

F/A-18 HORNET MMP CODES

672	R ENG VIBRATION ACCEL	873	R POWER CONTACTOR
673	RESERVED - R ENG FUEL FLOW SIG	880	UTILITY BATTERY
674	R FUEL TEMP	881	BATTERY CHARGER
675	R ENG COMPRESSOR DISC PRESSURE	882	EMERGENCY BATTERY
676	R ENG TURBINE DISC PRESSURE	883	EMERGENCY BATTERY CHARGER
677	R ENG INLET TEMP	884	GROUND POWER CIRCUIT
678	R ENG OIL PRESSURE	885	BATTERY RELAY CONTROL UNIT
682	TEST VALVE	888	TEST VALVE
702	L ENG LEVEL 3 EGT OVERTEMP	895	CANOPY SWITCHES DISAGREE
703	L ENG FAN VIBRATION HIGH	890	R MLG WOW SWITCH
704	L ENG COMPRESSOR VIBRATION	891	L MLG WOW SWITCH
706	L ENG OIL PRESSURE HIGH	892	NLG WOW SWITCH
707	L ENG OIL PRESSURE LOW	893	R MLG DOWNLOCK SWITCH
709	L ENG LEVEL 2 EGT OVERTEMP	894	L MLG DOWNLOCK SWITCH
710	L ENG LEVEL 2 FAN OVERSPEED	895	NLG DOWNLOCK SWITCH
711	L ENG LEVEL 2 FAN OVERSPEED	896	R MLG UPLOCK SWITCH
712	L ENG LEVEL 1 FAN OVERSPEED	897	L MLG UPLOCK SWITCH
713	L ENG LEVEL 3 COMPRESSOR OVERSPEED	898	NLG UPLOCK SWITCH
714	L ENG LEVEL 2 COMPRESSOR OVERSPEED	899	LAUNCH BAR RETRACT SWITCH
715	L ENG LEVEL 1 COMPRESSOR OVERSPEED	80A	REPLACE MISSION CARD
716	L ENG FLAMEOUT	900	L GCU EMERGENCY POWER
718	L ENG HUNG STALL	901	L MLG PLAN LINK SWITCH
730	RESERVED - L ENG THRUST LOW	902	R MLG PLAN LINK SWITCH
752	R ENG LEVEL 3 EGT OVERTEMP	903	HARD LANDING DATA - LEVEL 1
753	R ENG FAN VIBRATION HIGH	904	HARD LANDING DATA - LEVEL 2
754	R ENG COMPRESSOR VIBRATION	905	ANTI-SKID TRANSDUCER BOX
756	R ENG OIL PRESSURE HIGH	906	ANTI-SKID CONTROL VALVE
757	R ENG OIL PRESSURE LOW	907	L ANTI-SKID TRANSDUCER
759	R ENG LEVEL 2 EGT OVERTEMP	908	R ANTI-SKID TRANSDUCER
760	R ENG LEVEL 3 FAN OVERSPEED	910	R MLG UPLOCK DID NOT OCCUR
761	R ENG LEVEL 2 FAN OVERSPEED	911	L MLG UPLOCK DID NOT OCCUR
762	R ENG LEVEL 1 FAN OVERSPEED	912	NLG UPLOCK DID NOT OCCUR
763	R ENG LEVEL 3 COMPRESSOR OVERSPEED	915	LANDING GEAR CONTROL UNIT (L GCU)
764	R ENG LEVEL 2 COMPRESSOR OVERSPEED	916	ARRESTING GEAR PRESSURE LOW
765	R ENG LEVEL 1 COMPRESSOR OVERSPEED	925	A/C NEG G OVERSTRESS
766	R ENG FLAMEOUT	926	STRAIN GAUGE RECORDING TERMINATED
768	R ENG HUNG STALL	927	G-LIMIT FUNCTION OVERRIDDEN
780	RESERVED - R ENG THRUST LOW	928	9G ENABLED
800	APU OVERSPEED	941	FUEL DUMP VALVE FAILED OPEN
801	APU OVERHEAT	942	R FUEL SOV
802	APU NO FLAME	943	L FUEL SOV
803	RESERVED - APU START	944	FUEL X-FEED SOV
804	APU TIMED OUT	945	INTERNAL FUEL XFER SYS LEVEL I
805	APU FUEL SOV FAILED TO OPEN	946	INTERNAL FUEL XFER SYS LEVEL II
809	MU FULL	947	INTERNAL FUEL XFER SYS LEVEL III
810	RESERVED - NCTR TURNED OFF	948	INTERNAL FUEL XFER SYS LEVEL IV
811	A/C POSITIVE OVERSTRESS	951	EXT TANK OVER PRESSURE
812	MAG TAPE/MU/MAINT PC CARD FULL	980	L ENG OIL LEVEL LOW
813	L ANTI-ICE	981	R ENG OIL LEVEL LOW
814	R ANTI-ICE	982	L AMAD OIL LEVEL LOW
815	INLET ICE DETECTOR	983	R AMAD OIL LEVEL LOW
816	L AMAD OIL PRESSURE LOW	984	APU OIL LEVEL LOW
817	R AMAD OIL PRESSURE LOW	985	RLCS LEVEL LOW OR OVERFILLED
818	L ATSCV OPEN	988	FIRE EXTINGUISHER LEVEL LOW
819	R ATSCV OPEN	995	FLUIDS TEST COMPLETE
820	ACS TEMP/FLOW CONTROLLER	996	LOX LEVEL LOW (40%)
821	CABIN AIRFLOW/TEMP SENSOR	997	HYD-1 OIL LEVEL LOW
822	AVIONICS AIRFLOW/TEMP SENSOR	998	HYD-2 OIL LEVEL LOW
823	SUIT/CABIN TEMP CONTROL	999	HYD FLUID LEVEL NABIT NOT DONE
824	SYSTEM SUPPLY AIRFLOW INCORRECT	ALQ	ALQ-165 FAIL
825	CABIN AIRFLOW INCORRECT	C01	MU/MISSION CARD CLASSIFIED
826	ECS AIRFLOW TO RLCS AIRFLOW VALVE	C02	MC1 CLASSIFIED
827	CABIN TEMPERATURE INCORRECT	C03	MC2 CLASSIFIED
828	RLCS TEMP SENSOR	C04	SMS CLASSIFIED
829	ECS DELIVERY AIR TEMP INCORRECT	C05	WEAPONS CLASSIFIED
830	VENT SUIT TEMP SENSORS	C06	CLASSIFIED AMU
831	BLEED AIR LEAK/DETECTION FAILURE		
832	PRIMARY BLEED AIR OVERPRESSURE		
833	SECONDARY BLEED AIR OVERPRESSURE		
834	PITOT HEATER CIRCUIT FAIL		
835	R PITOT HEATER CIRCUIT FAIL		
836	L FWD COCKPIT/AVI FAN OVERHEAT		
837	R FWD COCKPIT/AVI FAN OVERHEAT		
838	L AFT COCKPIT/AVI FAN OVERHEAT		
839	R AFT COCKPIT/AVI FAN OVERHEAT		
840	RLCS FILTER OVERPRESSURE		
841	RLCS PRESSURE LOW		
842	RLCS HEAT EXCHANGER OR FAN		
843	RLCS DOOR		
844	RLCS TEMP HIGH		
845	CABIN EXIT AIR CONTROLLER		
846	CABIN EXIT AIR VALVE		
847	CABIN EXIT AIR PRESSURE LOW		
848	AVI UNDERCOOL WARNING TEMP SENSOR		
849	AFT EQUIPT BAY COOLING FAN OVERHEAT		
853	ATARS FWD TEMP SENSOR		
854	ATARS MID TEMP SENSOR		
855	ATARS COOLING TEMP SENSOR		
856	AVI COOLING PRESSURE SENSOR		
857	ATARS HEATING VALVE		
858	ATARS COOLING VALVE		
859	ATARS RADAR VALVE		
860	SENSOR BAY TEMP INLET SOV		
861	ANTI FOG SYSTEM CONTROLLER		
870	L GCU		
871	R GCU		
872	L POWER CONTACTOR		

MAY III™ v8.1.D. - DATED 6/15/05 - PAGE 16

THIS MANUAL IS NOT WORD - THIS IS ONLY A QUICK REFERENCE - ALWAYS USE TECHNICAL PUBLICATIONS

F/A-18 HORNET FCS BLIN CODES

(X=0 or 4)

X001	* FCC PROM DEVICE CODE	X177	AP/NWS DISENGAGE (PADDLE) SWITCH
X002	* FCC CPU REGISTER	X200	SPIN RECOVERY SWITCH
X003	* FCC VARIABLE RAM	X202	FCC YAW TRIM
X004	* FCC CHECKSUM	X203	* FCC AILERON DEL COMMAND
X005	* FCC NONVOLATILE MEMORY	X204	* FCC FAIL ROLL CSSA
X006	* FCC DISCRETE BUS	X206	* FCC RUDDER DEL COMMAND
X007	* FCC CPU	X207	* FCC LEF
X010	* FCC ANALOG WRAP AROUND	X210	* FCC RIGHT TEF SOV LOGIC
X011	* FCC INSTRUCTION SET TEST	X211	* FCC LEFT TEF SOV LOGIC
X012	FCC CHANNEL IDENT	X212	* FCC RIGHT STAB LOGIC
X015	* FCC SOV DRIVER INIT TEST	X213	* FCC LEFT STAB LOGIC
X016	% FCC POWER SUPPLY SHORTED	X215	* FCC ADS
X017	* FCC MUX TERMINAL	X241	NWS EHV/FCC
X020	FCC FAIL RATIO CHANGER TEST	X242	PLC (THROTTLE) EHV/FCC
X021	J3/J5 OR J10/J12 CABLE	X243	AILERON EHV/FCC
X022	NWS CABLE	X246	RUDDER EHV/FCC
X023	J1/J11 OR J4/J9 CABLE	X247	LEF EHV/FCC
X024	RATE GYRO CABLE	X250	R TEF EHV/FCC
X025	FOREIGN CHANNEL POWER OFF	X251	L TEF EHV/FCC
X026	ACCELEROMETER CABLE	X252	R STAB EHV/FCC
X030	ADS CABLE	X253	L STAB EHV/FCC
X032	AFT RUDDER PED CABLE	X261	RATIO CHANGER INTERFACE
X033	X CHANNEL POWER OFF	X262	PITCH TRIM ACTUATOR FAIL
X034	FWD RUDDER PED CABLE	X263	@ AILERON ACTUATOR INTERFACE
X035	STICK SENSOR CABLE	X265	NWS ACTUATOR POSITION
X036	STICK GRIP CABLE	X266	RUDDER ACTUATOR INTERFACE
X040	FCS CONTROL PANEL CABLE	X267	LEF ACTUATOR INTERFACE
X041	* FCC ARITHMETIC TEST	X270	RIGHT TEF ACTUATOR INTERFACE
X042	* FCC PARITY TEST	X271	LEFT TEF ACTUATOR INTERFACE
X043	* FCC NONVOLATILE MEMORY	X272	RIGHT STAB ACTUATOR INTERFACE
X044	* FCC MEMORY TEST	X273	LEFT STAB ACTUATOR INTERFACE
X046	* FCC BLEED AIR DR/NH LOCKUP FAIL	X301	LEF IN/OUTBOARD POSITION
X047	* FCC CROSS CHANNEL DATA LINK	X302	LEF MCV POSITION
X050	* FCC ACTIVE PARITY/MEMORY TEST	X303	AILERON MCV POSITION
X051	* FCC WING FOLD CONTROL LOGIC	X304	RUDDER MCV POSITION
X052	TAKE-OFF TRIM LOGIC	X305	RUDDER PEDAL POSITION
X053	NOSE GEAR DOWN SWITCH	X306	YAW TRIM (SWITCH) POSITION
X054	L GEAR DOWNLOCK SWITCH	X307	LEF ASYMMETRY BRAKE INTERFACE
X055	R GEAR DOWNLOCK SWITCH	X311	RUN TG-7
X056	NOSE GEAR WOW SWITCH	X312	RUN TG-10
X057	L GEAR WOW SWITCH	X313	PITCH TRIM MOTOR POSITION
X060	R GEAR WOW SWITCH	X314	LEF HDU POSITION (DO NOT RUN EXERCISE MODE OR TG-6, USE LEF UNLOCK PROCEDURE ONLY)
X062	LEF ASYMMETRY	X315	LONGITUDINAL STICK POSITION
X063	STAB/RUDDER SWITCHING VALVE	X316	LATERAL STICK POSITION
X064	LEF ASYMMETRY BRAKE	X317	NWS POSITION
X066	AILERON SW VALVE (FOLD/UNFOLD WINGS)	X320	LEF ASYMMETRY BRAKE CONT (DO NOT RUN EXERCISE MODE OR TG-6, USE LEF UNLOCK PROCEDURE ONLY)
X067	LEF SWITCHING VALVE	X321	AOA POSITION
X070	RUDDER PRESSURE SWITCH	X322	\$ THROTTLE FORCE
X071	AILERON PRESSURE SWITCH	X323	AILERON INTERFACE
X072	LEF PRESSURE SWITCH	X324	AOA STUCK PROBE (CHECK PROBE)
X073	NOSE GEAR DOWN SWITCH	X326	RUDDER INTERFACE
X074	L GEAR DOWN SWITCH	X327	LEF INTERFACE
X075	R GEAR DOWN SWITCH	X330	% RIGHT TEF INTERFACE
X076	NOSE GEAR WOW SW (CHECK SERVICING)	X331	% LEFT TEF INTERFACE
X077	L WOW SWITCH (CHECK SERVICING)	X332	% RIGHT STAB INTERFACE
X100	R WOW SWITCH (CHECK SERVICING)	X333	% LEFT STAB INTERFACE
X101	TRIM LEFT/RIGHT SWITCH	X336	\$ PLC (THROTTLE) POSITION
X102	TRIM LEFT SWITCH	X337	NWS TRACKING
X103	TRIM RIGHT SWITCH	X343	FCC CHANNEL OFF TEST
X104	* FCC PITCH TRIM RELAY TEST	X344	FCC ASYMMETRY SENSOR
X105	* FCC PITCH TRIM LEFT SWITCH	X345	FCC ASYMMETRY BRAKE
X106	* FCC PITCH TRIM RIGHT SWITCH	X346	FCC ASYMMETRY BRAKE RELAY DRIVER
X107	* FCC PITCH TRIM UP SWITCH	X347	FCC ASYMMETRY DETECTOR
X110	* FCC RICH TRIM DOWN SWITCH	X351	* FCC SPEED BRAKE CONTROL
X114	TRIM UP SWITCH	X353	* FCC ATC ENGAGE LOGIC
X115	TRIM UP/DOWN SWITCH	X355	* PITCH TRIM MOTOR FAILS T/O TRIM
X116	TRIM DOWN SWITCH	X356	* FCC FAILED NWS SOV ON LOGIC
X121	NWS ENGAGE SWITCH	X357	* FCC NWS SOV OFF LOGIC
X123	LAUNCH BAR EXTEND SWITCH	X360	FCC FAIL TRIM RELAY TEST
X124	\$ ATC ENGAGE/DISENGAGE SWITCH	X361	* FCC FOREIGN CHANNEL EXIT
X134	MASTER CAUTION LAMP RESET SWITCH	X362	* FCC PITCH RATE SENSOR
X135	GROUND POWER SWITCH	X363	* FCC ROLL RATE SENSOR
X137	SPEED BRAKE RETRACT DISCRETE	X364	* FCC YAW RATE SENSOR
X140	SPEED BRAKE EXTEND DISCRETE	X365	FCC NORMAL ACCEL SENSOR
X145	RECEE CONFIG DISCRETE	X366	FCC LATERAL ACCEL SENSOR
X153	TAKE-OFF TRIM SWITCH	X367	* FCC FAIL UNIMPLEMENTED MEM TEST
X155	FCS RESET SWITCH	X370	* FCC FAIL CARD SEAT TEST
X162	FCS BIT CONSENT SWITCH	X371	FCC FAIL MUX TERM MEMORY TEST
X164	FLAP SWITCH (AUTO)	X373	FCC FAIL CHANNEL SYNC TEST
X165	FLAP SWITCH (FULL)	X374	FCC FOREIGN CHANNEL BACKGROUND
X166	FLAP SWITCH (HALF)	X375	MUX TERMINAL SHUTDOWN MON TEST
X170	GAIN ORIDE SWITCH		
X172	TRIM SWITCH		
X176	WING FOLD UNLOCK PROX SWITCH		

MAY III™ v8.1.D. - DATED 6/15/05 - PAGE 17

THIS MANUAL IS NOT WORD - THIS IS ONLY A QUICK REFERENCE - ALWAYS USE TECHNICAL PUBLICATIONS

F/A-18 HORNET FCS BLIN CODES

(X=0 or 4)

X404	ROLL STK POS FAIL - VALUE TEST	X612	FCC RATE SENSOR ROLL AMP TEST
X405	PITCH STK POS FAIL + VALUE TEST	X614	FCC RATE SENSOR ROLL MEAS RLY TEST
X406	ROLL STK POS FAIL + VALUE TEST	X616	* FCC RATE SENSOR ROLL TORQ TOL TEST
X407	YAW TRIM POT FAIL X-CH POSITION	X621	* RATE SENSOR YAW NULL TEST
X410	RUDDER PEDAL SENSOR	X622	RATE SENSOR YAW TORQUE TEST
X411	PITCH STK POS FAIL - VALUE TEST	X623	RATE SENSOR YAW TORQUE VALUE TEST
X412	PITCH STK POS FAIL NULL TEST	X624	RATE SENSOR YAW REV TORQUE TEST
X413	PITCH STK POS SENSOR X-CH POSITION	X625	RATE SENSOR YAW NORM TOL TEST
X414	ADS SENSOR INTERFACE	X626	RATE SENSOR YAW TORQUE TOL TEST
X415	ROLL STK POS SENSOR	X632	FCC RATE SENSOR YAW AMP TEST
X416	ROLL STK POS FAIL NULL TEST	X634	FCC RATE SENSOR YAW MEAS RLY TEST
X420	* PROGRAM INCOMPATIBILITY TEST	X636	FCC RATE SENSOR YAW TORQ TOL TEST
X422	PITCH RATE GYRO SENSOR	X641	* ACCEL NORMAL NULL TEST
X423	ROLL RATE GYRO SENSOR	X642	ACCEL NORMAL TORQUE TEST
X424	YAW RATE GYRO SENSOR	X643	ACCEL NORMAL TORQUE VALUE TEST
X425	NORMAL ACCELEROMETER SENSOR	X644	ACCEL NORMAL REV TORQUE TEST
X426	LATERAL ACCELEROMETER SENSOR	X645	ACCEL NORMAL NORM TOL TEST
X427	% RATE GYRO SPEED TEST	X646	ACCEL NORMAL TORQUE TOL TEST
X461	* FCC PITCH STK BIT SWITCH	X652	FCC ACCEL NORMAL AMP TEST
X462	* FCC PITCH STK A/D CONVERTER	X654	FCC ACCEL NORMAL MEAS RLY TEST
X463	* FCC PITCH STK A/D CONVERTER	X656	FCC ACCEL NORMAL TORQ TOL TEST
X465	* FCC WINGFOLD OPEN RELAY TEST	X661	* ACCEL LATERAL NULL TEST
X466	* FCC WINGFOLD CLOSED RELAY TEST	X662	ACCEL LATERAL TORQUE TEST
X467	* FCC PITCH TRIM BIT SWITCH	X663	ACCEL LATERAL TORQUE VALUE TEST
X470	* FCC PITCH TRIM BUFFER TEST 1	X664	ACCEL LATERAL REV TORQUE TEST
X471	* FCC PITCH TRIM BUFFER TEST 2	X665	ACCEL LATERAL NORM TOL TEST
X472	FCC SPEED BRAKE TEST	X666	ACCEL LATERAL TORQUE TOL TEST
X500	* MECH LOGIC FAIL - STABS OFF	X672	FCC ACCEL LATERAL AMP TEST
X501	* WATCHDOG MON TEST LOGIC FLAG1	X674	FCC ACCEL LATERAL MEAS RLY TEST
X502	* WATCHDOG MON TEST LOGIC FLAG2	X676	FCC ACCEL LATERAL TORQ TOL TEST
X503	* POWER TURN-ON RESET FAIL TEST	X701	RIG FAIL L TEF (RUN M-BIT)
X504	* COMPUTER CONTROLLED RESET	X702	RIG FAIL R TEF (RUN M-BIT)
X505	* WATCHDOG MON LOW GAIN DRIVER	X703	RIG FAIL LEF (RUN M-BIT)
X507	* FCC NWS PASSIVE SOV DRIVER	X704	RIG FAIL AILERON (RUN M-BIT)
X510	* FCC NWS FAIL POSITION NULL TEST	X705	RIG FAIL RUDDER (RUN M-BIT)
X511	* FCC NWS FAIL CURRENT NULL TEST	X706	RIG FAIL R STAB (RUN M-BIT)
X512	* FCC NWS SOV DRIVER	X707	RIG FAIL L STAB (RUN M-BIT)
X513	* FCC NWS BIT SWITCH TEST	X711	* FCC BATTERY BACKUP TURN OFF
X514	* FCC NWS POSITION A/D CONVERTER 1	X712	* FCC BATTERY BACKUP TURN ON
X515	* FCC NWS POSITION A/D CONVERTER 2	X713	* FCC BATTERY BACKUP LATCH TIME
X516	* FCC NWS SOV	X714	* FCC ACTIVE POWER SUPPLY
X517	NWS + CURRENT AMP TEST	X715	* FCC PASSIVE POWER SUPPLY
X520	NWS - CURRENT AMP TEST	X716	* FCC A/C POWER SUPPLY TEST (TG-1)
X521	* FCC APC ENGAGE LOGIC TEST	X721	OPERATOR ERROR - ADS SWITCH
X522	* FCC THROTTLE FORCE LVDT NORMAL	X722	OPERATOR ERROR - RESET SWITCH
X524	* FCC THROTTLE FORCE LVDT LOW	X723	OPERATOR ERROR - NWS SWITCH
X525	* FCC THROTTLE FORCE BIT SWITCH	X725	OPERATOR ERROR - FLAP SWITCH
X526	* FCC THROTTLE FORCE A/D CONVERTER 1	X731	OPERATOR ERROR - PLC POSITION
X527	* FCC THROTTLE FORCE A/D CONVERTER 2	X737	FOREIGN CHANNEL BACKGROUND
X530	* FCC PLC POSITION BIT SWITCH	X740	FOREIGN CHANNEL EXIT FLAG
X531	* FCC PLC POSITION A/D CONVERTER 1	X743	NWS LVDT TRACKING
X532	* FCC PLC POSITION A/D CONVERTER 2	X744	NWS ACTUATOR DRIVE RIGHT TEST
X533	* PLC RVDT MONITOR NORMAL	X745	NWS ACTUATOR DRIVE LEFT TEST
X534	* PLC RVDT MONITOR LOW	X746	NWS ACTUATOR DRIVE RIGHT TEST
X535	* PLC SERVOAMP + CURRENT TEST	X747	NWS ACTUATOR DRIVE LEFT TEST
X536	* PLC RVDT MONITOR LOW	X750	NWS ACTUATOR DRIVE RIGHT TEST
X537	* PLC ENGAGE ATTEMPT	X751	NWS SOV INTERNAL LEAK TEST
X540	* PLC THROTTLE BIT SWITCH	X753	PITCH TRIM ACTUATOR FAIL + LIMIT
X543	AOA SENSOR RVDT TRACKING	X754	PITCH TRIM ACTUATOR FAIL - LIMIT
X544	ADS SENSOR FAIL PSI TEST 1	X761	PLC ACTUATOR FAIL INIT SETTING
X545	ADS SENSOR FAIL PSI TEST 2	X762	PLC ACTUATOR FAIL RVDT
X546	ADS SENSOR FAIL PSI TEST 3	X763	PLC ACTUATOR FAIL + DRIVE
X547	ADS SENSOR FAIL PSI TEST 4	X764	PLC ACTUATOR FAIL + STOP
X552	* FCC ADS TRACKING TEST	X765	PLC ACTUATOR FAIL - DRIVE
X553	* FCC ADS TRACKING TEST	X766	PLC ACTUATOR FAIL - STOP
X554	* FCC ADS TRACKING TEST	X767	PLC ACTUATOR DISENGAGE TRANSIENT
X555	* FCC AOA BIT SWITCH TEST	X770	PLC FAIL DISENGAGE SOV TEST
X556	* FCC AOA BIT AMP TEST 1	X771	ATC SWITCH FAIL INITIAL CONDITION
X557	* FCC AOA BIT AMP TEST 2	X772	ATC SWITCH FAIL MANUAL START
X561	* RATE SENSOR PITCH NULL TEST	X773	\$ THROTTLE FORCE FAIL
X562	RATE SENSOR PITCH TORQUE TEST	X774	\$ THROTTLE FORCE LVDT FAIL NULL
X563	RATE SENSOR PITCH TORQUE VALUE TEST	X775	THROTTLE FORCE LVDT FAIL + FORCE
X564	RATE SENSOR PITCH REV TORQUE TEST	X776	THROTTLE FORCE LVDT FAIL - FORCE
X565	RATE SENSOR PITCH NORM TOL TEST	5002	# MECH SYSTEM FAIL ROLL RIGHT
X566	RATE SENSOR PITCH TORQUE TOL TEST	5003	# MECH SYSTEM FAIL PITCH UP
X572	FCC RATE SENSOR PITCH AMP TEST	5004	# MECH SYSTEM FAIL ROLL LEFT
X574	FCC RATE SENSOR PITCH MEAS RLY TEST	5005	# MECH SYSTEM FAIL PITCH DOWN
X576	* FCC RATE SENSOR PITCH TORQ TOL TEST	5006	PITCH TRIM DOWN SWITCH
X601	* RATE SENSOR ROLL NULL TEST	5007	YAW TRIM ROTATE LEFT TEST
X602	RATE SENSOR ROLL TORQUE TEST	5010	RUDDER PEDAL PUSH RIGHT TEST
X603	RATE SENSOR ROLL TORQUE VALUE TEST	5011	YAW TRIM ROTATE RIGHT TEST
X604	RATE SENSOR ROLL REV TORQUE TEST	5012	RUDDER PEDAL PUSH LEFT TEST
X605	RATE SENSOR ROLL NORM TOL TEST	5013	ROLL TRIM RIGHT SWITCH FAIL
X606	RATE SENSOR ROLL TORQUE TOL TEST	5015	ROLL TRIM LEFT SWITCH FAIL

MAY III™ v8.1.D. - DATED 6/15/05 - PAGE 18

THIS MANUAL IS NOT WORD - THIS IS ONLY A QUICK REFERENCE - ALWAYS USE TECHNICAL PUBLICATIONS

F/A-18 HORNET FCS SYNC CODES

(X = 1 LEFT STAB, 2 RIGHT STAB, 3 LEFT TEF, 4 RIGHT TEF)

5017 PITCH UP SWITCH FAIL
 5021 * FCC RATIO CHANGER DRIVER TEST 2/4
 5022 * FCC RATIO CHANGER DRIVER TEST 2/4
 5023 * FCC RATIO CHANGER DRIVER TEST 1/3
 5024 * STICK STOP ACTIVE DRIVER
 5025 * STICK STOP LEFT STAB FAIL INHIBIT
 5026 * STICK STOP RIGHT STAB FAIL INHIBIT
 5027 * STICK STOP FAILED TO ACTIVATE
 5030 * STICK STOP FAILED TO DISABLE
 5031 RATIO CHANGER FAIL CH4 DRIVE TEST
 5032 RATIO CHANGER FAIL CH2 DRIVE TEST
 5033 # MECH SYSTEM FAILED (LOW GAIN) RIG TEST
 5034 # MECH SYSTEM FAILED STK FORWARD TEST
 5035 # MECH SYSTEM FAILED STK AFT TEST
 5036 # MECH SYSTEM FAILED STK LEFT TEST
 5037 # MECH SYSTEM FAILED STK RIGHT TEST

FCS SYNC CODES

X0000 TEST GROUP BYPASSED - NO TESTS RUN
 X0002 * FCC FAILED SERVO OFF TEST
 X0003 * FCC BIT SWITCH FAILURE
 X0004 FCC FOREIGN CHANNEL ON TEST
 X0005 * FCC DP CIRCUIT FAILURE
 X0006 * FCC DP CIRCUIT FAILURE (ACT IF ALL 4 CH)
 X0011 * FCC RAM A/D CONVERTER TEST
 X0012 * FCC CAS A/D CONVERTER TEST
 X0013 * FCC RAM A/D CONVERTER TEST
 X0014 * FCC CAS A/D CONVERTER TEST
 X0016 ACTUATOR RAM POSITION - NOT TRACKING
 X0017 ACTUATOR CAS POSITION - NOT TRACKING
 X0020 * FCC SERVO AMP RELAY TEST
 X0021 ACTUATOR POSITION DRIFT (ACT)
 X0022 ACTUATOR POSITION DRIFT (ACT)
 X0023 * FCC SERVO AMP RELAY TEST
 X0025 * FCCA 3 FAIL LOGIC TEST
 X0026 * FCCB 3 FAIL LOGIC TEST
 X0041 % ACT INTERFACE FAIL SOV BIT RESET
 X0042 * ACT INTERFACE FAIL DP BIT RESET (ACT IF 2+ CH)
 X0043 * FCC FAILED ACTIVE LOGIC TEST
 X0044 FCC FOREIGN CHANNEL ON TEST
 X0060 * FCC FAILED 2 CHANNEL ON TEST (CH2)
 X0061 * FCC FAILED 2 CHANNEL ON TEST (CH1)
 X0062 * FCC FAILED 2 CHANNEL ON TEST (CH1)
 X0063 * FCC FAILED 2 CHANNEL ON TEST (CH4)
 X0064 * FCC FAILED 2 CHANNEL ON TEST (CH4)
 X0065 * FCC FAILED 2 CHANNEL ON TEST (CH3)
 X0066 * FCC FAILED 2 CHANNEL ON TEST (CH3)
 X0067 * FCC FAILED 2 CHANNEL ON TEST (CH2)
 X0070 * FCC FAILED 2 CHANNEL ON TEST (CH1)
 X0071 * FCC FAILED 2 CHANNEL ON TEST (CH3)
 X0072 * FCC FAILED 2 CHANNEL ON TEST (CH4)
 X0073 * FCC FAILED 2 CHANNEL ON TEST (CH2)
 X0101 * SERVOAMP MCV POS (ACT IF ALL 4 CH)
 X0107 RAM OR CAS POS TRACKING
 X0110 * ACTUATOR FAILED TO DRIVE (ACT IF 2+ CH)
 X0111 SERVOAMP CURRENT LOW LEVEL CMD CH 3/4
 X0112 * MCV CAS LOW LEVEL COMMAND CH 3/4
 X0113 * MCV CAS HIGH LEVEL COMMAND 3/4
 X0115 * SERVOAMP CURRENT LOW LEVEL CMD CH 3/4
 X0116 * MCV CAS LOW LEVEL COMMAND CH 3/4
 X0117 * MCV CAS HIGH LEVEL COMMAND CH 3/4
 X0121 SERVOAMP CURRENT LOW LEVEL CMD CH 1/2
 X0122 * MCV CAS LOW LEVEL COMMAND CH 1/2
 X0123 * MCV CAS HIGH LEVEL COMMAND 1/2
 X0125 * SERVOAMP CURRENT LOW LEVEL CMD CH 1/2
 X0126 * MCV CAS LOW LEVEL COMMAND CH 1/2
 X0127 * MCV CAS HIGH LEVEL COMMAND CH 1/2
 X0142 * FCC CURRENT MONITOR TEST
 X0145 * FCC CURRENT MONITOR TEST
 X0150 * FCC CURRENT MONITOR TEST
 X0153 * FCC CURRENT MONITOR TEST
 X0161 * CH 1 DP FAIL DRIVE TEST
 X0163 CH 1 RAM/MCV CAS LVDT TRACKING
 X0164 CH 1 ACTUATOR FAILED TO DRIVE (ACT)
 X0165 * CH 1 SERVOAMP FAILED DRIVE TEST
 X0167 * CH 2 DP FAIL DP DRIVE TEST
 X0171 CH 2 RAM/MCV CAS LVDT TRACKING
 X0172 CH 2 ACTUATOR FAILED DRIVE (ACT)
 X0173 * CH 2 SERVOAMP FAILED DRIVE TEST
 X0176 * CH 3 DRIVE TEST SETUP
 X0200 CH 3 RAM/MCV CAS LVDT TRACKING
 X0201 CH 3 ACTUATOR FAILED DRIVE (ACT)
 X0202 * CH 3 SERVOAMP FAILED DRIVE TEST

MAY III™ v8.1.D. - DATED 6/15/05 - PAGE 19

THIS MANUAL IS NOT WORD - THIS IS ONLY A QUICK REFERENCE - ALWAYS USE TECHNICAL PUBLICATIONS

F/A-18 HORNET FCS SYNC CODES

50246 FCC CURRENT MONITOR CIRCUITRY
 50247 FCC REMOTE SERVO COMMAND INPUT
 50251 * FCC CURRENT MONITOR DETECTOR
 50301 NO MORE TEST RUN DUE TO OTHER CH FAIL
 50305 ALL CH DRIVE TEST SETUP (*WITH 4207)
 50306 * ALL CH DRIVE TEST COMMAND WRAPAROUND
 50310 ALL CH DRIVE TEST HDU FAILED RESPONSE
 50311 ALL CH DRIVE TEST CAS FAILED RESPONSE
 50312 ALL CH DRIVE TEST RAM FAILED RESPONSE
 50313 ALL CH DRIVE TEST MCV FAILED NULL
 50314 ALL CH DRIVE TEST REMOTE CH OFF
 50321 NO MORE TEST RUN DUE TO OTHER CH FAIL
 50325 CH 1/2 DRIVE TEST SETUP FAILURE
 50326 * CH 1/2 DRIVE TEST COMMAND WRAPAROUND
 50327 CH 1/2 DRIVE TEST MCV POSITION FAIL
 50330 CH 1/2 DRIVE TEST HDU FAILED RESPONSE
 50331 CH 1/2 DRIVE TEST CAS FAILED RESPONSE
 50332 CH 1/2 DRIVE TEST RAM FAILED RESPONSE
 50333 CH 1/2 DRIVE TEST MCV FAILED NULL
 50334 CH 1/2 DRIVE TEST REMOTE CH OFF
 50341 NO MORE TEST RUN DUE TO OTHER CH FAIL
 50345 CH 3/4 DRIVE TEST SETUP FAILURE
 50346 * CH 3/4 DRIVE TEST COMMAND WRAPAROUND
 50347 CH 3/4 DRIVE TEST MCV POSITION FAIL
 50350 CH 3/4 DRIVE TEST CAS FAILED RESPONSE
 50351 CH 3/4 DRIVE TEST RAM FAILED RESPONSE
 50352 CH 3/4 DRIVE TEST MCV FAILED NULL
 50353 CH 3/4 DRIVE TEST CAS FAILED NULL
 50354 CH 3/4 DRIVE TEST REMOTE CH OFF
 50360 * SOV OFF RESPONSE TEST SETUP FAIL
 50361 SOV INTERNAL LEAK TEST
 50421 * ASYMMETRY FAILURE
 50422 * ASYMMETRY DETECTOR
 50423 * FCC FAIL MCV CAS RVDT SUM MONITOR
 50424 * FCC FAIL MCV CAS RVDT SUM BIT SWITCH
 50425 * FCC FAIL MCV CAS LVDT
 60000 RUD TEST GROUP BYPASSED - NO TESTS RUN
 60002 * FCC FAILED SERVO DRIVER OFF TEST
 60041 RAM POSITION LVDT SUM (*WITH 4207)
 60042 * RAM POSITION LVDT SUM MONITOR
 60043 * RAM POSITION LVDT SUM MONITOR
 60044 * RAM POSITION LVDT SUM MONITOR
 60045 * RAM POSITION LVDT SUM MONITOR
 60046 * PARTNER CH SERVOAMP INDICATED OFF
 60060 NO MORE TEST RUN DUE TO OTHER CH FAIL
 60061 * FCC CAS POSITION BIT SWITCH SHORTED
 60062 * FCC CAS POSITION FAIL BIT NULL TEST 1
 60063 * FCC CAS POSITION FAIL BIT NULL TEST 2
 60070 NO MORE TEST RUN DUE TO OTHER CH FAIL
 60101 * FCC RAM POSITION BIT SWITCH SHORTED
 60102 * FCC RAM POSITION FAIL BIT NULL TEST 1
 60103 * FCC RAM POSITION FAIL BIT NULL TEST 2
 60110 RAM POSITION LVDT TRACKING
 60120 NO MORE TEST RUN DUE TO OTHER CH FAIL
 60121 * FCC PEDAL FORCE BIT SWITCH SHORTED
 60122 * FCC PEDAL FORCE FAIL BIT NULL TEST 1
 60123 * FCC PEDAL FORCE FAIL BIT NULL TEST 2
 60130 PEDAL FORCE LVDT TRACKING
 60141 * FCC YAW TRIM BIT SWITCH SHORTED
 60142 * FCC YAW TRIM FAIL BIT NULL TEST 1
 60143 * FCC YAW TRIM FAIL BIT NULL TEST 2
 60150 YAW TRIM LVDT TRACKING
 60202 % RUD INTERFACE FAILED INITIAL BIT RESET
 60203 * RUD REMOTE CURRENT OUTPUT
 60210 RUD SERVOAMP ON DISCRETE FAILURE
 60211 * FCC REMOTE INPUT CURRENT
 60222 * FCC CURRENT MONITOR DETECTOR CH 1/3
 60224 * FCC CURRENT MONITOR DETECTOR CH 1/3
 60225 * FCC CURRENT REMOTE CURRENT CH 1/3
 60226 FCC CURRENT MONITOR CIRCUITRY
 60227 RUD REMOTE CURRENT INPUT FAILED
 60231 * FCC CURRENT MONITOR DETECTOR
 60242 * FCC CURRENT MONITOR DETECTOR
 60244 * FCC CURRENT MONITOR DETECTOR
 60245 * FCC CURRENT REMOTE OUTPUT
 60246 FCC CURRENT MONITOR CIRCUITRY
 60247 FCC REMOTE CURRENT INPUT
 60251 * FCC CURRENT MONITOR DETECTOR
 60301 NO MORE TEST RUN DUE TO OTHER CH FAIL
 60305 ALL CH DRIVE TEST SETUP (*WITH 4206)
 60306 * ALL CH DRIVE TEST COMMAND WRAPAROUND
 60310 ALL CH DRIVE TEST FAIL RESPONSE - ACT W/4266
 60311 ALL CH DRIVE TEST CAS FAILED RESPONSE
 60312 ALL CH DRIVE TEST RAM FAILED RESPONSE
 60313 ALL CH DRIVE TEST MCV FAILED NULL
 60314 ALL CH DRIVE TEST REMOTE CH OFF

MAY III™ v8.1.D. - DATED 6/15/05 - PAGE 20

THIS MANUAL IS NOT WORD - THIS IS ONLY A QUICK REFERENCE - ALWAYS USE TECHNICAL PUBLICATIONS

F/A-18 HORNET FCS SYNC CODES

70321 NO MORE TEST RUN DUE TO OTHER CH FAIL
 70325 * CH 1/2 DRIVE TEST SETUP FAILURE
 70326 CH 1/2 DRIVE TEST COMMAND WRAPAROUND
 70327 CH 1/2 DRIVE TEST MCV POSITION FAIL
 70330 CH 1/2 DRIVE TEST AIL RESPONSE
 70331 CH 1/2 DRIVE TEST CAS FAILED RESPONSE
 70332 CH 1/2 DRIVE TEST RAM FAILED RESPONSE
 70333 CH 1/2 DRIVE TEST MCV FAILED NULL
 70334 CH 1/2 DRIVE TEST REMOTE CH OFF
 70341 NO MORE TEST RUN DUE TO OTHER CH FAIL
 70345 * CH 3/4 DRIVE TEST SETUP FAILURE
 70346 * CH 3/4 DRIVE TEST COMMAND WRAPAROUND
 70347 * CH 3/4 DRIVE TEST MCV POSITION FAIL
 70350 CH 3/4 DRIVE TEST CAS FAILED RESPONSE
 70351 CH 3/4 DRIVE TEST CAS FAILED RESPONSE
 70352 CH 3/4 DRIVE TEST RAM FAILED RESPONSE
 70353 * CH 3/4 DRIVE TEST MCV FAILED NULL
 70354 CH 3/4 DRIVE TEST REMOTE CH OFF
 70360 * SOV OFF RESPONSE TEST SETUP FAIL
 70361 SOV INTERNAL LEAK TEST (ACT)
 70421 * AIL DEL FAILURE
 70422 * AIL HYD PRESSURE LOGIC
 70423 * AIL FAIL LOGIC CIRCUIT
 70424 * AIL DEL FAILURE
 70425 * AIL DEL FAILURE
 70426 * AIL ROLL STICK DEL LOGIC
 70427 * RUD PEDAL OR YAW TRIM X-TRACKING
 70430 * AIL DEL LOGIC
 70431 * AIL PEDAL DEL LOGIC
 70432 * AIL ROLL STICK WRAPAROUND
 70433 * AIL ROLL STICK FAIL NULL
 70434 * AIL DEL WRAPAROUND
 70435 * AIL DEL ON LOGIC FAILURE
 70436 * RUD DEL WRAPAROUND
 70441 AIL/RUD DEL ON LOGIC FAILURE
 70442
 THRU *AIL/RUD DEL ON LOGIC FAILURE
 70500

FCS BLIN AND SYNC NOTES:

* CHANGE CORRESPONDING FCC
 # IGNORE ON FCC IDENT 86, 99, OR 113, REQUIRES ACTION ON FCC IDENT 107, 91C AND UP
 % FCC SWAP NOT RECOMMENDED
 \$ REQUIRES NO MAINTENANCE FOR FLIGHT, BUT ATC USE IS PROHIBITED
 @ IF BIT WAS RUN WITH WINGS FOLDED/UNLOCKED, IBIT BLINS 4263 AND 70261 REQUIRE NO MAINTENANCE. IF WINGS WERE SPREAD/LOCKED DURING BIT FAILURE. MAINTENANCE IS REQUIRED.

F/A-18 HORNET APG-65 RADAR BOA CODES

CPS
 001 DATA PATHS ERROR
 002 PC & MAR TEST FAIL
 003 CONSTANTS PROM TEST FAIL
 004 OMM PROM CHECKSUM FAIL
 007 MICRO PROGRAM PARITY ERROR
 008 NP & SP WORD TEST FAIL
 009 NP & SP BLOCK TEST FAIL
 010 DISPLAY MUX TEST FAIL
 011 D/DO TEST FAIL
 013 A & C ALU TEST FAIL
 016 RTS RDP STAND ALONE MODE
 017 TWS OVERLAY CHECKSUM FAIL
 019 OMM CHECKSUM FAIL
 020 VARIABLE MEMORY CHECKSUM FAIL
 021 IOC FAIL
 022 IOC/IOB FAILURE
 023 IOC MICRO PROM PARITY ERROR
 025 EXCESSIVE PARITY ERROR
 029 MC MESS 30 DROP-OUT INPUT ERROR

RTDP
 033 PROGRAM MEMORY PARITY ERROR
 034 PROCESS SYNC TIMING FAIL
 035 DISPLAY SYNC TUNING FAIL
 036 POWER FAILURE
 037 BULK MEMORY PARITY ERROR
 038 MUX TEST REPLY FAIL
 039 DATA AND MEMORY TEST FAIL
 041 CPS TRANSFER FAIL
 042 DATA MEMORY 0 TEST FAIL
 043 DATA MEMORY 1 FAIL
 044 DATA MEMORY 2 FAIL
 046 NON-COMPATIBLE RTDP
 047 POST PROCESSING MODULE
 048 AIR TO AIR PPM TIMEOUT

R/E
 049 MUX TEST REPLY FAIL
 050 58 MHz I/Q DETECT FAIL
 051 MUX TEST DELAYED REPLY FAIL
 052 HARMONIC PHASE LOCK LOOP FAIL
 053 OFFSET PHASE LOCK LOOP FAIL
 054 TD POWER NORMAL FAIL
 055 VFO I/Q REF FAIL
 056 REF OSC OVEN TEMP FAIL
 060 MAIN CHAN INTERNAL NOISE FAIL
 061 GUARD CHAN INTERNAL NOISE FAIL

XMTR
 065 R-MUX REPLY FAIL
 066 WAVEGUIDE IN FLOOD POSN FAIL
 067 WAVEGUIDE IN DUMMY LOAD POSN FAIL
 068 WAVEGUIDE IN MAIN POSN FAIL
 069 WAVEGUIDE SWITCH INTERLOCK FAIL
 070 CONTROL ELECTRONICS TEST FAIL
 071 FLAT LEAKAGE FAIL
 072 LOW VOLTAGE FAIL
 073 RF POWER DEGRADED
 074 NO RF POWER
 075 FAULT
 076 HIGH VOLTAGE ARC
 077 CATHODE UNDER VOLTAGE
 078 GRID BIAS FAIL
 079 FILAMENT OVER VOLTAGE
 080 TIME OUT FAIL
 081 INVALID RF POWER
 082 DEGRADED RF SAT LOOP
 083 DUMP SAT LOOP
 084 RF POWER RATIO FAIL
 085 GATE PULSE RECEIVED FAILED
 086 POWER SUPPLY TRANSIENT
 087 LAUNCH INIT AIM-120 FAIL

R/E
 088 RFI> THRESHOLD P/G CALIBRATION
 089 RFI> THRESHOLD VFO CALIBRATION

XMTR
 090 ADC OUT PUT LINES TEST FAIL

091 FLASHING IRON CROSS TEST
 092 WAVEGUIDE ARC
 093 DATA LINK TEST ABORT
 094 58.22 MHz CLOCK FAIL
 095 THRESHOLDED GRID PULSE
 096 MISSILE TUNE ABORT

ANTENNA
 097 MUX TEST REPLY FAIL
 098 AZIMUTH A/D/A FAULT
 099 ELEVATION A/D/A FAULT
 100 STAB LOOP MONITOR FAULT
 103 FRAME TIME FAIL
 104 MOTOR ENABLE FAULT
 105 5 VOLT FAIL
 106 START OF SCAN TEST
 107 BAR DEVIATION FAIL
 108 SCAN MOTION TIMER EXPIRED
 109 NULL HORN DIODE FAIL
 110 PENCIL/FAN BEAM DRIVE FAIL
 111 RF INTERLOCK CHECK FAIL
 112 PENCIL/SPOILED BEAM FAIL

R/E
 113 PHASE/GAIN INCORRECT BIT SIGNAL
 114 PHASE/GAIN INCORRECT SIGNAL
 115 PHASE/GAIN 15 dB CAGC TEST FAIL
 116 PHASE/GAIN POST COMBINER GAIN FAULT
 117 PHASE/GAIN POST COMBINER PHASE FAULT
 118 PHASE/GAIN PRECOMBINER GAIN FAULT
 119 PHASE/GAIN AZ/EL GAIN FAIL

ANTENNA
 120 PHASE/GAIN AZ/EL PHASE FAIL

R/E
 121 PHASE/GAIN SUM BALANCE
 122 PHASE/GAIN SUM BALANCE
 123 PHASE/GAIN INSUF PHASE COMPENSATION
 124 PHASE/GAIN PHASE FAIL
 125 A/D OFFSET BIAS Q1
 126 A/D OFFSET BIAS I1
 127 A/D OFFSET BIAS Q2
 128 A/D OFFSET BIAS I2
 129 FMR INSUF SIGNAL LEVEL
 130 FMR SLOPE FAIL
 131 FMR LINEARITY FAIL
 132 FMR EXCESSIVE CORRECTION
 133 ZRD INCORRECT SIG LVL BIT TGT
 134 ZRD RANGE FAIL BIT TGT
 135 ZRD INCORRECT SIG LVL XMTR SIG
 136 ZRD RANGE FAIL - XMTR SIGNAL
 137 ZRD INCORRECT SIGNAL LVL
 138 ZRD TARGET RANGE OUT OF SPEC
 140 A/D BIAS JITTER FAULT
 141 A/D BIAS PARITY FAULT
 143 VFO CALIBRATION INSUF SIG LVL
 144 VFO CALIBRATION FREQ BIAS FAULT

STATUS
 145 BIT-IN-TEST
 146 EQUIPMENT NO-GO
 147 INITIATED BIT COMPLETE
 148 INDICATED BIT/ORT MAN TERMINATED
 149 IBIT/ORT INCOMPLETE
 150 RUN I-BIT
 151 TRANSMITTER TEST INCOMPLETE
 152 ANTENNA GYRO TEST SKIPPED
 153 R/E EXCESSIVE RF DETECTED
 154 EMERGENCY ACTIVATED
 155 WOW/IN-FLT DISAGREE
 156 PRESENT MODE FAIL
 157 PRESENT CHANNEL FAIL
 158 TA FAIL
 160 UNIQUE TEST COMPLETE
 161 RTDP FAIL
 162 XMTR FAIL
 163 R/E FAIL
 164 RTDP FAIL
 165 ANTENNA FAIL
 166 ANTENNA SERVO FAIL

F/A-18 HORNET APG-65 RADAR BOA CODES

167 XMTR FLOW LOW
168 WAVEGUIDE PRESSURE LOW
169 LAUNCH INITIATE FAIL
170 RTDP OVERHEAT
171 XMTR OVERHEAT
172 R/E OVERHEAT
173 CPS OVERHEAT
174 ANTENNA OVERHEAT
175 UNIQUE TEST FAIL
176 UNIQUE TEST IN PROGRESS

MC CHANNEL FAIL ADVISORIES

177 RTDP OVERHEAT
178 XMTR OVERHEAT
179 R/E OVERHEAT
180 CPS OVERHEAT
181 ANTENNA OVERHEAT
182 - 208 R/E OR XMTR MC CHANNEL FAILURES

XMTR ADVISORIES

209 PRIME PWR OVER CURRENT
210 ION PUMP PWR SUPPLY FAULT
211 FILAMENT OVER VOLTAGE
212 FILAMENT UNDER VOLTAGE
213 INTERPULSE BODY CURRENT FAULT
214 PEAK BODY CURRENT FAULT
215 HIGH VOLTAGE SUPPLY FAULT
216 GRID BIAS FAULT
218 WAVEGUIDE SWITCH INTERLOCK FAIL
220 LOW VOLTAGE FAULT
221 HIGH VOLTAGE ARC

CPS ADVISORIES

225 TASKED I/O FAILED TO COMPLETE-1
226 TASKED I/O FAILED TO COMPLETE-2
227 TASKED I/O FAILED TO COMPLETE-3
228 TASKED I/O FAILED TO COMPLETE-4
229 - 232 ID HEX CODE 4 (BITS) 232 = LSB
233 - 240 ID HEX CODE 8 (BITS) 240 = LSB

CPS

241 OMM UPPER MEMORY TEST FAIL
242 TASKED IOC ALU TEST FAIL
243 A&C X-Y REG PLA TEST FAIL
244 A&C 2801 TWO PORT RAM FAIL
245 A&C ALU FAIL
246 USER CONDITION CODES FAIL
247 INSTRUCTION SET TEST FAIL
248 INTERRUPTS TEST FAIL
249 NOTE PAD MEMORY TEST FAIL
250 SCRATCH PAD MEMORY TEST FAIL
251 IOB MEMORY TEST FAIL
252 OMM LOWER MEMORY TEST FAIL
253 DISC TO IOB CHECKSUM FAIL
254 EPROM SCRATCH TRACK FAIL
255 DISC READ ERROR
256 MEM PARITY LOGIC TEST FAIL
257 READ/WRIGHT TRACK P/G HISTORY
258 DISC I/O FAILED TO COMPLETE
259 DISC TO RTDP XFER READ ERROR
260 DISC TO RTDP XFER FAILED TIMEOUT
261 PARITY ERROR BOOT UP
262 WATCHDOG ERROR BOOT UP
264 EEPROM SCRATCH TRK BATTERY FAIL
265 DISCRETE INTERRUPTS TEST
266 DISCRETE INPUTS TEST
267 DISCRETE OUTPUTS TEST
268 R-MUX INTERNAL LOOP
269 R-MUX CONTROL WORD
270 R-MUX X&R LINES
271 MUX INTERNAL LOOP
272 MUX DMA ADDR REG
273 MUX CONTROL WORD FAIL
274 FORMATTING LOGIC TEST
275 WATCHDOG TIMER FAIL
276 DISPLAY MUX LOOP TEST
277 DISPLAY MUX 1 MHz TEST
278 IOB TO DISC TRANSFER FAIL
280 LOOP COUNTER INST REG FAIL
281 FAILED TO LOAD RTDP GROUP 1
282 FAILED TO LOAD RTDP GROUP 2
283 FAILED TO LOAD RTDP GROUP 3

284 FAILED TO LOAD RTDP GROUP 4
285 HISTORY FILE WRITE FAIL
286 A&C PROM SCAN TEST
287 IOC PROM SCAN TEST
288 PROGRAM MEM LOAD FAIL IQI

RTDP

289 INSTRUCTIONS OR DATA PIPELINE FAIL
290 B REG LATCH OR TEST REG
291 RPT & BCTX INSTS & COUNTERS DM PTRS
292 STATUS REG LATCHED BITS RESET TEST
293 TEST REG & INSTS SELF TEST FAIL
294 X-MEM & BRANCH INST TEST FAIL
295 DATA MEM ADDRESS LINES FAIL
296 DATA MEM ADDRESS POINTERS TEST FAIL
297 DATA MEM PTR MASKING/AUTO INCREMENT
298 RTDP/CMEM/RTDP LOOP TEST
299 X-MEMORY R/W CONFLICT RESOLUTION
300 PRESET DESTINATION REG
301 COMPARE AND TRANS INST ON B REG
302 INSTRUCTION SET GROUP 1 TEST
303 INSTRUCTION SET GROUP 2 TEST
304 B-REGISTER TEST FAIL
305 BULK MEM CONTROLLER RAM AND PTR TEST
306 BULK MEM CONTROLLER PORT 2
307 BULK MEM CONTROLLER PORT 3
308 BULK MEM AUTO REFRESH
309 BULK MEM TEST
310 DISPLAY INTERFACE TEST FAIL
311 PREPACKER AND DIGITAL AGC TEST
312 TIMING AND CONTROL TEST 1/2
313 PPM CONFIDENCE TEST FAIL
314 PPM TEST FAIL
315 STATUS REG/SEN SW TEST FAIL
316 TC TIMER FAIL
317 T & C TIMING TEST
318 RTDP/CPS/CHEM/CPS LOOP TEST
319 LOADER READY FAIL
320 FILES CHECKSUM FAIL

R/E

321 MAIN BOARD A/D OFFSET CONTROL
322 GUARD CH A/D OFFSET CONTROL
323 A/D BIAS V/BW TEST FAIL
324 AGC PARITY FAIL
325 MAIN CH INTERNAL NOISE
326 GUARD CH INTERNAL NOISE
327 MAIN CH NOISE DIODE TEST FAIL
328 GUARD CH NOISE DIODE TEST FAIL
329 TD POWER MONITOR FAIL
330 EXCESSIVE TD LEAKAGE
331 NO MAIN CH BIT TARGET
332 NO AZ CH BIT TARGET
333 BIT TARGET LEVEL
334 MAIN GUARD CH GAIN BALANCE FAIL
335 DELTA EL CH BIT TARGET LEVEL FAIL
336 GUARD CH BIT TARGET FAIL
337 MAIN CHANNEL DAGC TEST
338 GUARD CHANNEL DAGC TEST
339 CAGC OVERRIDE TEST FAIL
340 BIT TD ATTN TEST FAIL
341 BLANKING TEST FAIL
342 IF COMBINER MAIN CH FAIL
343 IF COMBINER DELTA CH
344 VIDEO BANDWIDTH MAIN CH FAIL
345 VIDEO BANDWIDTH GUARD CH FAIL
346 LOCAL OSCILLATOR PHASE SHIFTER
347 VFO FREQ 130 KHz
348 VFO FREQ -50 KHz
349 30 dB CAGC MAIN CH FAIL
350 30 dB CAGC GUARD CH FAIL
351 15 dB CAGC MAIN CH FAIL
352 15 dB CAGC GUARD CH FAIL
353 PC WIDEBAND GAIN
354 PC NARROW BAND GAIN
355 IF MONITOR ALWAYS ENABLED
356 IF MONITOR 1 TEST FAIL
357 IF MONITOR 1 AND 2 TEST FAIL
358 LPRF BLANKING TEST FAIL
359 58 MHz LEAKAGE FAIL
360 IF MONITOR 1 AND 2 TEST FAIL
361 BLANKING TRANSIENT
362 BLANKING TEST AGC DETECTED

F/A-18 HORNET APG-65 RADAR BOA CODES

364 I/Q REFERENCE DETECTOR FAIL
365 CH OFFSET PHASED LOCKED LOOP FAIL
366 CH HARMONIC PHASE LOCKED LOOP FAIL
367 CH TD POWER NORMAL FAIL
368 PHASE LOCK FAIL CHANNEL 16
369 - 400 R/E RF CHANNELS FAIL

481 - 512 R/E OR XMTR RF CHANNELS FAIL

XMTR

401 30 dB CAGC SIGNAL AMPLITUDE
402 SIGNAL TO NOISE RATION
403 TO SPUR TEST FAIL
404 LO SPUR TEST FAIL
405 EXCESSIVE NOISE FLOOR
406 RB1/RB2 EXCESSIVE VARIATION
411 RFI PRESENT - ALL CHANNELS
412 R/E TEST SKIPPED
413 LOOK-THRU COMMANDED
414 ELECTRONICS SELT TEST FAIL
415 WAVEGUIDE IN MAIN POSITION
416 RFI PRESENT - 15 OR MORE CHANNELS
417 MICROPROCESSOR MEMORY FAIL
418 LOW RF POWER FOR LPRF
419 NO RF POWER FOR LPRF
420 DUMPED IN LPRF
421 LOW RF POWER FOR HPRF
422 NO RF POWER FOR HPRF
423 DUMPED IN HPRF
424 LOW RF POWER FOR PDI
425 NO RF POWER FOR PDI
426 DUMPED IN PDI
427 GATE PULSE FAIL
429 MICROPROCESSOR ATTN INVALID
430 DUMPED DURING SAT LOOP CAL
431 POWER INTERRUPT TRIGGER INHIBIT
432 DEGRADED RF PWR DURING SAT LOOP CAL

ANTENNA

433 AZIMUTH A/D/A FAIL
434 ELEVATION A/D/A FAIL
435 AZIMUTH SCAN DEVIATION
436 ELEVATION SCAN DEVIATION
437 MOTOR RELAY DISABLE
438 VSWR FAIL
439 AZIMUTH SCAN TEST
441 AZIMUTH +58° POSN FAIL
442 AZIMUTH +70° ALIGN FAIL
443 AZIMUTH -58° POSN FAIL
444 AZIMUTH -70° ALIGN FAIL
445 ELEVATION +45° POSN FAIL
446 ELEVATION +60° ALIGN FAIL
447 ELEVATION -45° POSN FAIL
448 ELEVATION -60° ALIGN FAIL
449 AZIMUTH GAIN ADJ 1, 0 FAIL
450 AZIMUTH GAIN ADJ 0, 1 FAIL
451 AZIMUTH GAIN ADJ 1, 1 FAIL
452 AZIMUTH CAGE TEST FAIL
453 ELEVATION CAGE TEST FAIL
457 AZIMUTH TORQUER AMP FAIL
458 ELEVATION TORQUER AMP FAIL
459 AZIMUTH CONDITIONAL FEEDBACK FAIL
461 AZIMUTH DRAFT TEST FAIL
462 ELEVATION DRIFT TEST FAIL
463 AVERAGE AZIMUTH SCAN FAIL
464 AVERAGE ELEVATION SCAN FAIL

I-BIT ADVISORY

465 RTDP PPM NOT INSTALLED
466 RTDP GROUP 1 TEST TIMER BLOW OUT
467 RTDP GROUP 2 TEST TIMER BLOW OUT
468 RTDP GROUP 1 TEST TIMER BLOW OUT
469 RTDP GROUP 4 TEST TIMER BLOW OUT
470 RTDP TEST # OUT OF LIMITS GROUP 1
471 RTDP TEST # OUT OF LIMITS GROUP 2
472 RTDP TEST # OUT OF LIMITS GROUP 3
473 RTDP TEST # OUT OF LIMITS GROUP 4
474 RTDP MODE CHANGE FAIL # 1
475 CPS DL2 TIME UP RTDP TEST
476 XMTR WOW SET
477 RTDP MODE CHANGE FAIL # 2
478 RTDP TEST FAILED TO COMPLETE
479 RTDP IQI BIT ERROR RATE FAIL
480 CPS UPPER OMM MEMORY TEST BYPASSED

F/A-18 HORNET APG-73 RADAR BOA CODES

GENERAL

001 BIT-IT TEST
 002 EQUIPMENT NO-GO
 003 INITIATED BIT COMPLETE
 004 IBIT/ORT MANUALLY TERMINATED
 005 IBIT/ORT INCOMPLETE
 006 RUN IBIT
 007 RADAR XMTR TEST INCOMPLETE
 008 ANTENNA GYRO TEST SKIPPED
 009 RFI DETECTED
 010 EMERGENCY ACTIVATED
 011 EQUIPMENT DEGRADE
 012 PRESENT MODE FAIL
 013 PRESENT CHANNEL FAIL
 014 TERRAIN AVOIDANCE FAIL
 015 WOW SET
 016 RDP TEST STATION STAND ALONE FAIL
 017 CPS FAIL
 018 RADAR TRANSMITTER FAIL
 019 RECEIVER FAIL
 020 RDP FAIL
 021 ANTENNA FAIL
 022 SERVO ELECTRONICS GIMBAL ASSY FAIL
 023 TRANSMITTER LOW COOLANT FLOW
 024 WAVEGUIDE PRESSURE LOW
 025 LAUNCH INITIATED AIM-7 FAIL
 026 CPS FAIL
 027 RADAR TRANSMITTER FAIL
 028 RECEIVER FAIL
 029 RDP FAIL
 030 SERVO ELECTRONICS GIMBAL ASSY FAIL
 031 LAUNCH INITIATE AIM-120 FAIL
 032 WOW/INFLIGHT DISAGREE

RDP

033 EEPROM CHECKSUM FAIL
 034 EEPROM CHECKSUM FAIL
 035 WATCHDOG ERROR
 036 WATCHDOG ERROR
 037 WORKING MEMORY DATA TEST FAIL
 038 WORKING MEMORY DATA TEST FAIL
 039 INSTRUCTIONS AND BUILT-IN FUNCTIONS TEST
 040 INSTRUCTIONS AND BUILT-IN FUNCTIONS TEST
 041 MACHINE ERROR
 042 AVIONIC MUX INPUT MESSAGE 30 FAIL
 043 -047 INPUT OUTPUT CHANNEL ERROR
 048 "RUG II" RDP MOTION SENSOR SUBSYSTEM FAIL
 049 SIGNAL PROCESSOR (SP) CLOCK TEST FAIL
 050 SP LOADER FAIL
 051 PROCESS SYNC TIMING FAIL
 052 SP INPUT TEST FAIL
 053 "RUG II" MOTION SENSOR SUBSYSTEM FAIL
 054 SP ANALOG TO DIGITAL TRANSFER TEST FAIL
 055 SP GRAPH TEST FAIL
 056 SP GLOBAL BULK MEMORY CHECKSUM TEST
 057 SP GLOBAL COMM MEMORY CHECKSUM TEST
 058 SP GLOBAL BULK MEMORY PARITY TEST FAIL
 059 SP PROGRAM MEMORY PARITY TEST FAIL
 060 SP DISPLAY SYNC TIMING TEST FAIL
 062 "RUG II" MOTION SENSOR SUBSYSTEM U-GYRO FAIL
 063 "RUG II" MOTION SENSOR SUBSYSTEM V-GYRO FAIL
 064 "RUG II" MOTION SENSOR SUBSYSTEM W-GYRO FAIL

RECEIVER

065 ANALOG SIGNAL (ASC) DC VOLTAGE TEST FAIL
 067 ASC/AUTOMATIC GAIN CONT BUS TRANS TEST
 068 ASC INPUT/OUTPUT SUBMODULE TEST FAIL
 069 ASC I/O BUS CHECKSUM TEST FAIL
 070 ASC BUS DATA REQUEST FAIL
 071 ASC TIMING AND CONT WIDEBAND TEST
 072 ASC TIMING AND CONT RANGE CLOSURE TEST
 073 ASC TIMING AND CONT WB INPHASE QUAD TEST
 074 ASC TIMING AND CONT NARROWBAND TEST FAIL
 075 ASC TIMING AND CONT NB INPHASE QUAD TEST
 076 ASC PROG EVENT GEN RAM SW WAIT T/O TEST
 077 ASC PULSE REPETITION INT BUFF MODULE TEST
 078 ASC DIGITAL AUTO GAIN CONT SUBMODE TEST
 079 ASC DIGITAL GAIN CONT RAM DATA TEST FAIL
 080 ASC VARIABLE FREQ OSC SUBMODULE TEST
 081 DC VOLTAGE TEST FAIL
 082 RADAR INTERNAL MUX INTERFACE TEST
 083 RMUX EXECUTE TEST FAIL

084 LOW NOISE AMPLIFIER BIAS TEST FAIL
 085 TRANSMITTER DRIVE POWER TEST FAIL
 086 ASC REFERENCE TEST FAIL
 087 FIRST LOCAL OSC POWER/PHASE LOCK TEST
 088 VOLTAGE CONT CRYSTAL OSC OVEN TEMP TEST
 089 FREQ SYNTHESIZER POWER FAIL
 090 VOLTAGE CONT CRYSTAL OSC REF SIGNAL TEST
 091 "13C&T" STRETCH SLOPE CONTROL FAIL
 092 "13C&T" STRETCH PEAK SIDE LOBE RATIO FAIL
 093 "13C&T" STRETCH RF POWER FAIL
 094 "13C&T" STRETCH SERIAL DATA PARITY FAIL
 095 "RUG II" MOTION SENSOR SUBSYSTEM OVERHEAT
 096 "RUG II" MOTION SENSOR SUBSYSTEM VOLTAGE FAIL

XMTR

097 RMUX INTERFACE TEST FAIL
 098 WAVEGUIDE SWITCH IN FLOOD POSITION
 099 WAVEGUIDE IN DUMMY LOAD POSITION
 100 WAVEGUIDE IN MAIN POSITION
 101 WAVEGUIDE SWITCH INTERLOCK FAIL
 102 CONTROL ELECTRONICS SELF TEST FAIL
 103 FLAT LEAKAGE FAULT
 104 LOW VOLTAGE FAULT
 105 RF POWER DEGRADED
 106 NO RF POWER
 107 XMTR FAULT
 108 HIGH VOLTAGE ARC FAULT
 109 CATHODE UNDER VOLTAGE
 110 GRID BIAS
 111 FILAMENT OVERVOLTAGE FAULT
 112 TIME OUT TEST
 113 DEGR RF POWER MULTICHANNEL SAT LOOP
 114 FAULT DURING MULTICHANNEL SAT LOOP
 115 GATE PULSE RECEIVED FAIL
 116 FLASHING IRON CROSS
 117 WAVEGUIDE ARC FAULT
 118 58.22 MHz CLOCK FAIL
 119 DATA LINK TEST ABORT
 120 MISSILE TUNE ABORT
 121 GATE PULSE FAULT

MISC

122 "RUG II" MOTION SEN SUBSYSTEM PERFORMANCE
 123 "RUG II" MOTION SEN SUBSYSTEM R ACCEL FAIL
 124 "RUG II" MOTION SEN SUBSYSTEM S ACCEL FAIL
 125 "RUG II" MOTION SEN SUBSYSTEM T ACCEL FAIL
 126 "RUG II" MOTION SEN SUBSYSTEM INERTIAL ELECT
 127 "RUG II" MOTION SENSOR SUBSYSTEM PROCESSOR
 128 "RUG II" MOTION SENSOR SUBSYSTEM INPUT/OUTPUT

ANTENNA

129 RMUX TEST REPLY FAIL
 130 AZIMUTH ANALOG TO DIGITAL/A FAULT
 131 ELEVATION ANALOG TO DIGITAL/A FAULT
 132 STABILIZATION LOOP MONITOR FAULT
 133 MOTOR ENABLE FAULT
 134 SV FAIL
 135 NULL HORN DIODE FAIL
 136 PENCIL/FAN BEAM DRIVE FAIL
 137 RF INTERLOCK FAIL
 138 PENCIL/FAN BEAM FAIL
 139 AZIMUTH POSITION MODE FAIL
 140 ELEVATION POSITION MODE FAIL
 141 AZIMUTH RATE MODE FAIL
 142 ELEVATION RATE MODE FAIL
 144 ELEVATION BAR DEVIATION TEST FAIL

RECEIVER

145 ASC DC OFFSET BIAS NB TEST FAIL
 146 ASC DC OFFSET DRIFT NB TEST FAIL
 147 ASC IN PHASE/QUAD GAIN SIGNAL LEVEL
 148 ASC IN PHASE/QUAD GAIN IMBALANCE
 149 ASC IN PHASE/QUAD PHASE IMBALANCE
 150 ASC DC OFFSET BIAS WB TEST FAIL
 151 ASC DC OFFSET DRIFT WB TEST FAIL
 152 ASC IN PHASE/QUAD GAIN SIGNAL LEVEL
 153 ASC IN PHASE/QUAD GAIN IMBALANCE WB
 154 ASC IN PHASE/QUAD PHASE IMBALANCE WB
 155 FREQ MOD RANGING +/- AVG SLOPE TEST
 156 FREQ MOD RANGING +/- LINEARITY FAIL
 157 - 160 CAGC TEST FAILS

F/A-18 HORNET APG-73 RADAR BOA CODES

161 FREQ MODULATION RANGING INSUFF SIGNAL
 162 FREQ MODULATION RANGING EXCESSIVE
 163 FREQ MODULATION RANGING AVG SLOPE
 164 FREQ MODULATION RANGING
 165 LOCAL OSC PHASE SHIFTER SIGNAL LEVEL
 166 LOCAL OSC PHASE SHIFTER LINEARITY TEST
 167 15dB COURSE AUTO GAIN CONTROL SIGNAL
 168 DIFFERENCE CH SIGNAL LEVEL TEST FAIL
 169 SUM CH SIGNAL LEVEL TEST FAIL
 170 MUTUAL CH SIGNAL LEVEL TEST FAIL
 171 MUTUAL CH XMTR DRIVE LEAKAGE TEST
 172 RFI FAILS
 173 RFI FAILS
 174 SUM/DIFFERENCE GAIN BALANCE TEST FAIL
 175 ANTENNA CHANNEL SELECTOR TEST FAIL
 176 RECEIVER/EXCITER BEACON RF CH 52 FAIL
 177 - 208 RF CHANNEL 51, 53 THROUGH 83 FAIL

TRANSMITTER

209 PRIME POWER OVERCURRENT FAIL
 210 ION PUMP POWER SUPPLY FAIL
 212 FILAMENT UNDERVOLTAGE FAIL
 213 INTERPULSE BODY CURRENT FAIL
 214 PEAK BODY CURRENT FAIL
 215 CATHODE OVERVOLTAGE FAIL
 216 GRID BIAS FAIL
 217 "13C&T" RECEIVER CAL NARROW BAND FAULT
 218 WAVEGUIDE SWITCH INTERLOCK FAIL
 219 "13C&T" RECEIVER CAL WIDE BAND FAULT
 220 LOW VOLTAGE FAIL
 221 HIGH VOLTAGE ARC FAIL
 222 "13C&T" STRETCH TRANSMITTER DRIVE SIG POWER
 223 "RUG II" MOTION SENSOR KALMAN FILTER WARNING
 224 "RUG II" MOTION SENSOR ALT LOOP WARNING

RDP

225 CPU-1 INTERRUPTS TEST FAIL
 226 CPU-2 INTERRUPTS TEST FAIL
 227 DISCRETE INTERRUPTS TEST FAIL
 228 I/O BUS CONTROLLER TEST FAIL
 229 ENERGIZER VOLTAGE FAIL
 230 CPU MEMORY CONT PAGE REG TEST
 231 CPU MEMORY CONT PAGE REG TEST
 232 CPU MEMORY CONT FAULT REGISTER
 233 CPU MEMORY CONT FAULT REGISTER
 234 CPU MEMORY CONT TRIMMER TEST
 235 CPU MEMORY CONT TRIMMER TEST
 236 BUILT-IN SELF TEST NOT COMPLETE
 241 WALL CLOCK TEST FAIL
 242 SP CHANNEL TEST FAIL
 243 1553 RADAR MUX CHANNEL TEST FAIL
 244 AVIONIC MUX CHANNEL TEST FAIL
 245 1553 RADAR MUX/AVI MUX LOOP TEST
 246 DISCRETE INPUTS TEST FAIL
 247 DISCRETE OUTPUTS TEST FAIL
 248 RMUX CHANNEL TEST FAIL
 249 LEFT DDI DATA/CLOCK CHANNEL TEST FAIL
 250 RIGHT DDI DATA/CLOCK CHANNEL TEST FAIL
 251 SP BUILT-IN SELF TEST TIME-OUT FAIL
 252 TEST INPUTS FAIL
 253 BUILT-IN SELF TEST CHECKSUM TEST FAIL
 254 SP SPURIOUS INTERRUPT
 261 SP CLOCK TEST
 262 SP INTERFACE TEST FAIL
 263 SP INTERFACE TEST FAIL
 264 SP ARRAY CONT CPU SELF TEST PROGRAM
 265 SP OVERLAY ROM DIRECT MEMORY ACCESS
 266 SP CPU PRIMITIVE INSTRUCTIONS TEST FAIL
 267 SP OVERLAY ROM CHECKSUM TEST FAIL
 268 SP GLOBAL COMM MEM ADDRESS/CELL TEST
 269 SP EXECUTE I/O CPU INSTRUCTION SET TEST
 270 SP GLOBAL COMM MEM WRITE PTER TEST
 271 SP GLOBAL COMM MEM DIR MEM ACCESS
 272 SP CPU INST SET TEST FAIL
 273 SP CPU INST SET TEST FAIL
 274 SP GLOBAL COMM MEM ADDR/CELL TEST FAIL
 275 SP INTERRUPT VECTORING TEST FAIL
 276 SP FAULT LOGIC AND REGISTER TEST FAIL
 277 SP ARRAY CONT AUX TIMER EXECUTION TEST
 278 SP ARRAY CONT CPU BUS ACCESS TEST FAIL
 279 SP WRITE POINTER TEST FAIL
 280 SP DIRECT MEM ACCESS CONT MEM TEST
 281 SP POINTER PORT/GLOBAL COMM MEM

282 SP MOD ISOLATION FNCT DIR MEM ACCESS
 283 SP SINGLE MOD PROC ELEMENT ARRAY
 284 SP SINGLE MOD PROC ELEMENT AUTO
 285 SP SINGLE MOD PROC ELEMENT AUTO
 286 SP SINGLE MOD PROC ELEMENT MEM PARITY
 287 SP SINGLE MOD PROC ELEMENT DYN INST
 289 SP SINGLE MOD PROC ELEMENT ARRAY CONT
 290 SP SINGLE MOD PROC ELEMENT SYSTEM
 291 SP GLOBAL BULK MEM COMPLEX SET SCAN
 293 SP GLOBAL BULK MEM CONT INIT TEST
 294 SP GLOBAL BULK MEM CONT TASK ARBITER PROM
 295 SP GLOBAL BULK MEM CONT RAM ADDR/CCELL
 296 SP GLOBAL BULK MEM CONT TASK PROM
 297 SP GLOBAL BULK MEM CONT SINGLE MOD
 298 SP GLOBAL BULK MEM ADDR/CCELL TEST
 299 SP GLOBAL BULK MEM CONT STR & SKEW
 300 SP GLOBAL BULK MEM CONT/MOD
 303 SP PRESSURER PULSE COMP TEST BUS
 304 SP PRESSURER PULSES APPLICATION
 305 SP PRESSURER PULSE COMP FIRST IN/OUT
 306 SP PRESSURER PULSE COMP AC BUS
 307 SP GLOBAL BULK MEM CONT PRESSURER
 309 SP PRESSURER PULSE COMP BULK MEM
 310 SP PRESSURER PULSE COMP DISCRETE
 311 SP DIGITAL SCAN CONVERTER TEST
 312 SP DIGITAL SCAN CONVERTER GENERATOR
 313 SP DIGITAL SCAN CONVERTER FIRST IN/OUT
 314 SP GLOBAL BULK MEM CONT DIGITAL SCAN
 315 SP DIGITAL SCAN CONVERTER ANALOG RDDI
 316 SP DIGITAL SCAN CONVERTER CUE PROM
 317 SP DIGITAL SCAN CONVERTER AC BUS
 318 SP DIGITAL SCAN CONVERTER TIMING GEN
 319 SP DIGITAL SCAN CONVERTER BULK MEM
 320 SP DIGITAL SCAN CONVERTER ANALOG TEST
 321 "RUG II" SP SPECIAL TEST EQPT/INST/RECCE RETURN
 322 "RUG II" SP SPECIAL TEST EQPT/INST/RECCE AC BUS
 323 "RUG II" SP SPECIAL TEST EQPT/INST/RECCE CLOOP
 324 "RUG II" SP SPECIAL TEST EQPT/INST/RECCE 1ST I/O
 325 "RUG II" SP SPECIAL TEST EQPT/INST/RECCE 1ST I/O
 326 "RUG II" SP GLOBAL MEM CONT EQPT/INST/RECCE
 327 "RUG II" SP SPECIAL TEST EQPT/INST/RECCE MEM
 328 "RUG II" SP SPECIAL TEST EQPT/INST/RECCE PHASE
 329 "RUG II" SP SPECIAL TEST EQPT/INST/RECCE MEM
 330 "RUG II" SP SPECIAL TEST EQPT/INST/RECCE PHASE
 331 SP SPECIAL TEST EQPT/INST/RECCE PARITY
 332 "RUG II" SP SPECIAL TEST EQPT/INST/RECCE MEM
 333 "RUG II" SP SPECIAL TEST EQPT/INST/RECCE SOURCE

RECEIVER

337 ASC TO RDP INTERFACE
 338 ASC POWER ON TEST
 339 ASC BUILT-IN TEST TIMEOUT TEST
 340 ASC RAM/ROM TEST
 341 PULSE REPETITION INTERVAL BUFFER TEST
 342 NB ANALOG TO DIGITAL FILTER TEST
 343 WB ANALOG TO DIGITAL FILTER TEST
 344 NB ANALOG TO DIGITAL SATURATION TEST
 345 WB ANALOG TO DIGITAL SATURATION TEST
 346 NB BARKER CODE (13:1) TEST
 347 WB BARKER CODE (7:1) TEST
 348 RANGE CLOSURE TEST
 349 DIGITAL AUTOMATIC GAIN CONT FORCE TEST
 350 DIGITAL AUTOMATIC GAIN CONT NB RMS
 351 DIGITAL AUTOMATIC GAIN CONT NB PEAK
 352 DIGITAL AUTOMATIC GAIN CONT SENSITIVITY
 353 DIGITAL AUTOMATIC GAIN CONT SENSITIVITY
 354 VARIABLE FREQUENCY OSCILLATOR TEST FAIL
 355 VIDEO FILTER BANDWIDTH TEST
 356 AMRAAM TEST
 358 ASC STATUS BITS TEST FAIL
 359 PULSE COMPRESSION BARKER CODE TEST
 360 ASC PROGRAMMABLE EVENT GEN RAM TEST FAIL
 361 TRANSMITTER DRIVE ATTENUATOR TEST
 362 ASC ATTENUATOR TIME OUT FAIL
 367 "13C&T" ANALOG SIGNAL CONVERTER BIT FAIL
 368 GAIN CONTROL AMP SATURATION TEST FAIL
 369 BUILT-IN SELF TEST TIMEOUT TEST
 375 RF CHANNEL TEST FAIL
 376 - 377 NOISE TESTS
 378 CONTROLLER SELF TEST FAIL

GENERAL

385 SUM CHANNEL SIGNAL LEVEL TEST

F/A-18 HORNET APG-73 RADAR

386 DIFFERENCE CHANNEL SIGNAL LEVEL
387 AZIMUTH/ELEVATION SIGNAL LEVEL TEST FAIL
388 AZIMUTH/ELEVATION PHASE TEST FAIL
389 - 390 30 dB COURSE AUTOMATIC GAIN CONTROL TEST
391 GUARD CHANNEL SIGNAL LEVEL TEST
392 ZERO RANGE DELAY BIT ANTENNA SIGNAL
393 ZERO RANGE DELAY BIT ANTENNA TARGET
394 ZERO RANGE DELAY BIT ANTENNA SIGNAL
395 ZERO RANGE DELAY TEST
396 ZERO RANGE DELAY TRANSMITTER SIGNAL TEST
397 ZERO RANGE DELAY TRANSMITTER RANGE FAIL
398 - 399 RECEIVER BLANKING TRANSIENTS SUM/DIFF
400 ANALOG TO DIGITAL DATA BUS LINES TEST
401 RECEIVER BLANKING GATE SIGNAL LEVEL TEST
402 RECEIVER BLANKING GATE DELAY TEST
403 TRANSMITTER GATE SIGNAL LEVEL
404 TRANSMITTER GATE DELAY TEST
405 TRANSMITTER DRIVE GATE SIGNAL LEVEL TEST
406 TRANSMITTER DRIVE GATE DELAY TEST FAIL
407 - 415 RECEIVER SENSITIVITY TESTS
416 RECEIVER ZERO DOPPLER LEAKAGE TEST
417 "13C&†" TRANSMITTER GATE PULSE FAULT
418 XMTR LOW RF POWER FOR LOW PRF
419 XMTR NO RF POWER FOR LOW PRF
420 XMTR DUMPED DURING LOW PRF
421 XMTR LOW RF POWER FOR HIGH PRF
422 XMTR NO RF POWER FOR PDI
423 XMTR DUMP DURING PDI
424 XMTR MICROPROCESSOR XMTR ATTN INVALID
425 XMTR POWER INTERRUPT TRIGGER INHIBIT
426 XMTR GATE PULSE FAIL
427 XMTR FLAT LEAKAGE TEST FAIL
428 "13C&†" WIDEBAND ZERO RANGE DELAY SIGNAL LVL
429 "13C&†" WIDEBAND ZERO RANGE DELAY CAL
430 "13C&†" WIDEBAND ZERO RANGE DELAY SIGNAL
432 MICROPROCESSOR XMTR NOT INSTALLED

ANTENNA

433 AZIMUTH DIG TO ANALOG & ANALOG TO DIG
434 ELEVATION DIG TO ANALOG & ANALOG TO DIG
435 AZIMUTH SCAN LINEARITY TEST
436 ELEVATION SCAN LINEARITY TEST FAIL
437 MOTOR RELAY FAIL
438 AZIMUTH ANGLE SYMMETRY TEST FAIL
439 AZIMUTH +58° POSITION FAIL
440 AZIMUTH +70° ALIGNMENT FAIL
441 AZIMUTH -58° POSITION FAIL
442 AZIMUTH -70° ALIGNMENT FAIL
443 AZIMUTH +45° POSITION FAIL
444 AZIMUTH +60° ALIGNMENT FAIL
445 AZIMUTH -45° POSITION FAIL
446 AZIMUTH -60° ALIGNMENT FAIL
447 RF INTERLOCK TEST FAIL
449 AZIMUTH GAIN ADJUSTMENT (1, 0) FAIL
450 AZIMUTH GAIN ADJUSTMENT (0, 1) FAIL
451 AZIMUTH GAIN ADJUSTMENT (0, 1) FAIL
452 AZIMUTH CAGE FAIL
453 ELEVATION CAGE FAIL
454 AZIMUTH TORQUER AMP FAIL
455 ELEVATION TORQUER AMP FAIL
456 AZIMUTH DRIFT FAIL
457 ELEVATION DRIFT FAIL
458 AVERAGE AZIMUTH SCAN FAIL
459 AVERAGE ELEVATION SCAN FAIL
462 AZIMUTH/ELEVATION POSITION ERROR TEST
463 ELEVATION SCAN LINEARITY TEST FAIL
464 ELEVATION SCAN LINEARITY TEST FAIL
465 UNIQUE PILOT TEST
466 UNIQUE PILOT TEST
467 UNIQUE PILOT TEST
479 "RUG II" MOTION SENSOR SUBSYSTEM OFF WARNING
480 "RUG II" RDP TO MOTION SENSOR SUBSYSTEM

RADAR BIT DESCRIPTIONS

APG-65 BIT DESCRIPTIONS

POWER-UP

0.0-3 ORT INITIALIZATION (INITIALIZATION)

COMPUTER POWER SUPPLY

1.0 THE SCHEDULER
1.1 WATCH DOG TIMER TEST
1.2 A AND C PROM SCAN TEST
1.3 X-Y REG PLA TEST
1.4 A AND C 2 PORT RAM TEST
1.5 A AND C ALU TEST
1.7 TASKED IOC ALU TEST
1.8 A AND C INTERRUPT TEST
2.0-1 UPPER OMM MEMORY TEST
3.0-1 LOWER OMM AND VARIABLE MEMORY TEST
4.0 THE SCHEDULER
4.1 DI/DO TEST
4.2 FIRM MEM/DISC TEST
4.3 EEPROM SCRATCH TEST
4.4 INTERNAL LOOP AND RMUX DATA IRQ TEST
4.5 CONTROL WORD LOGIC AND DECODER TEST
4.6 X AND R LINES AND RMUX DATA IRQ TEST
4.7 RTDP DMA ADDRESS REGISTER TEST
4.8 INTERNAL LOOP TEST
4.9 RTDP DMA ADDRESS REG TEST
4.10 FORMATTING LOOP TEST
4.11 DISPLAY MUX LOOP AND COMPARE TEST
4.12 ONE MHZ CLOCK TEST
4.13 INSTRUCTIONAL SET TEST

RADAR TARGET DATA PROCESSOR

5.0 RTDP TESTS/BASIC INITIALIZATION
5.1 CMEM LOOP TESTS
5.2 RDP/CMEM/RDP INTERFACE TESTS
5.3 LOAD GROUP 1 TESTS
5.4 GROUP 1 TESTS
5.5 LOAD GROUPS 2 TESTS
5.6 GROUPS 2 TESTS
5.7 LOAD GROUP 4 TESTS
5.8 GROUPS 4 TESTS/PPM TEST
5.9 LOAD TACT FILES CMEM
5.10 LOAD GROUP 3 TEST
5.11 GROUP 3 TESTS
5.12 LEAD RSP IQI FILE (IF IQI INSTALLED)
5.13 IQI B
5.14 LOAD GROUP 4
5.15 RUN GROUP 4 (AMRAAM)

ANTENNA

6.0 ANTENNA TESTS
6.1 PRIMARY TESTS
6.2 AZ GIMBAL ALIGNMENT TEST
6.3 ANTENNA POSITION TESTS
6.4 AZ/EL CAGE TESTS
6.5 GAIN ADJUST TESTS
6.7 ANTENNA DRIFT TESTS
6.8 AZ SCAN TESTS
6.9 ANTENNA EL SCAN TESTS

RADAR RECEIVER EXCITER

7.0 R/E TESTS (INITIALIZATION)
7.1 32 CHANNEL CALIBRATIONS
7.2 A/D BIAS COMPENSATIONS
7.3 58 MHZ LEAKAGE TEST
7.4 SIGNAL LEVEL TEST
7.5 VFO TESTS
7.6 LO PHASE SHIFTER CHECKS

7.7 PULSE COMPENSATION & ZERO DELAY
7.9 HOUSE KEEPING

RADAR TRANSMITTER

8.0 XMTR TESTS (INITIALIZATION)
8.1 WAVEGUIDE POSITION TESTS & CALS
8.2 TIMEOUT TEST
8.3 POWER TESTS/ZRD/LEAKAGE/IFM
8.4 VSWR TEST
8.5 MICRO PROCESSOR TEST
8.6 HOUSEKEEPING

OTHER

9.0 FAULT ISOLATION
10.0 RELAY MODE

APG-73 BIT DESCRIPTIONS

1 RDP (DATA PROCESSOR) IBIT
2 RDP (SIGNAL PROCESSOR) IBIT
3 RECEIVER (RECEIVER) IBIT
4 RECEIVER (ANALOG SIG CONVERTER) IBIT
5 ANTENNA (APG-65) IBIT
6 IBIT SYSTEMS TEST
7 RADAR TRANSMITTER (APG-65) IBIT
8 IBIT FAULT ISOLATION
9 RADAR DISPLAY RELAY MODE
10 MISSILE RETUNE TESTS
11 MISSILE RETUNE TESTS
12 AIM-120 DATA LINK TESTS
13 AIM-120 DATA LINK TESTS

F/A-18A/B/C/D

TYPE EQUIPMENT CODES: AMAA/AMAE/AMAF/AMAG

Do not assign an EOC code if all equipment is operational. The aircraft is OPC.

Assign alpha character (B) of the EOC code when the following system(s) are inoperative. The aircraft is FMC, M or S.

- AUTOMATIC DIRECTION FINDER SET
- CLOCK
- EXTERNAL POWER SYSTEM
- MAGNETIC COMPASS (AQU-3/A)
- STRIKE CAMERA SYSTEM (NOTE 1)
- VIDEO TAPE RECORDER (NOTE 1)

Assign alpha character (C) of the EOC code when the following system(s) are inoperative preventing the escort/strike mission. The aircraft is not capable of independent detection and destruction of aircraft/missiles under all-weather conditions or providing protective escort for strike and support forces using all air-to-air weapons in a multi-threat ECM environment. The aircraft is PMC, M or S.

- LAU-116 (NOTE 1)
- LAU-117 (NOTE 1)
- MISSILE ILLUMINATION GROUP SPARROW
- SPARROW MISSILE EJECTOR LAUNCHER

Assign alpha character (D) of the EOC code when the following system(s) are inoperative preventing the strike mission. The aircraft is not capable of conducting interdiction or war-at-sea missions using all weapons and delivery modes compatible with aircraft regardless of terrain, weather or enemy defenses. The aircraft is PMC, M or S.

- AMAC SYSTEM (NOTES 1,2)
- WEAPON CONTROL (HUD, MULTIPURPOSE DISPLAY GROUP) (NOTE 3)

Assign alpha character (J) of the EOC code when the following system(s) are inoperative preventing the visual attack mission. The aircraft is not capable of conducting missions under VMC, using system deliveries of conventional ordnance, conducting anti-radiation missile strike support, close air support for friendly forces with forward air controller. The aircraft is PMC, M or S.

- ACM (AWG-25) (HARM) (NOTE 1)
- ANTI-G SUIT PRESSURE
- ARMAMENT CONTROL PROC SET
- CENTERLINE PYLON (SUU-62) (NOTE 1)
- CHAFF COUNTERMEASURES SET (ALE-39) (NOTE 1)
- COUNTERMEASURES SET (ALQ-126 OR ALQ-165) (NOTE 1)
- DATA STORAGE UNIT
- DIGITAL MAP
- EW THREAT DISPLAY
- FLIR POD AND ADAPTER (NOTE 1)
- HAVEQUICK/SINCGARS (ARC-182)

F/A-18A/B/C/D (cont)

- HORIZONTAL INDICATOR (NOTE 4)
- LASER SPOT TRACKER AND ADAPTER (NOTE 1)
- LASER TARGET DESIGNATOR/RANGER (NOTE 1)
- NAVIGATION FLIR
- NIGHT VISION GOGGLES
- PALLETIZED GUN SYSTEM (M61A1)
- RADAR LIQUID COOLING SYSTEM
- RADAR SET (APG-65) (NOTE 4)
- RADAR WARNING RECEIVER (ALR-67) (NOTE 1)
- SELECTIVE STORES JETTISON SYSTEM
- SIDEWINDER MISSILE SYSTEM
- SIDEWINDER LAUNCHERS (LAU-7A) (NOTE 1)
- THREAT WARNING LIGHT DISPLAY GROUP
- WEAPON RELEASE RACKS (BRU-32/A or BRU-32A/A) (NOTE 1)
- WEAPON SYSTEM CONTROL FUNCTION (HOTAS) (NOTE 4)
- WING PYLONS (SUU-63) (NOTE 1)

Assign alpha character (K) of EOC code when the following system(s) are inoperative preventing the expanded mobility mission. The aircraft is not capable of safe movement on and off CV/SATs during day, night and inclement weather conditions, conducting independent navigation, using encrypted radio voice communications and IFF, or in-flight refueling (receive). The aircraft is PMC, M or S.

- AIR REFUELING PROBE
- AIR REFUELING PROBE FLOOD LIGHT
- ANGLE-OF-ATTACK SYSTEM AND INDEX LIGHTS
- APPROACH POWER COMPENSATOR SYSTEM
- BOARDING LADDER DRAG BRACE
- CATAPULT SYSTEM
- EMERGENCY JETTISON SYSTEM
- ILS RECEIVER/DECODER (ARA-63) (NOTE 5)
- MISSION COMPUTERS (BOTH REQUIRED)
- RADAR BEACON (APN-202) AND RT (1028/APN-202) (NOTE 5)
- RECEIVER TRANSMITTER PROCESSOR (RT-1379/ASW) (NOTE 5)
- SECONDARY POWER SUPPLY (APU)
- SECURE IFF (KIT 1A)(MODE 4) (NOTE 1)
- SECURE VOICE (KY-58) (NOTE 1)
- WING FOLD

Assign alpha character (L) of the EOC code when the following system(s) are inoperative preventing the IMC flight mission. The aircraft is not capable of day or night IMC field flight operations with necessary communications, IFF, navigation, flight and safety systems required by applicable NATOPS and FAA regulations. The aircraft is PMC, M or S.

- ALTIMETER, ELECTRONIC (APN-194(V))
- ENGINE ANTI-ICE SYSTEM
- EXTERIOR LIGHTING (POSITION AND FORMATION) (NOTE 6)
- IFF TRANSPONDER (APX-100(V))
- INTERIOR LIGHTING

F/A-18A/B/C/D (cont)

F/A-18A/B/C/D (cont)

MISSION COMPUTERS (AKY-I4)(MC1 REQUIRED)
PITOT/ANGLE-OF-ATTACK PROBE HEATER SYSTEM
TACTICAL NAVIGATION SET (ARN-118(V))
TAXI LIGHT
UP FRONT CONTROL
WINDSHIELD ANTI-ICE AND RAIN REMOVAL
WHEEL ANTI-SKID CONTROL SYSTEM

TECHNICAL DIRECTIVE COMPLIANCE (NOTE 11)

Assign alpha character (Z) of the EOC code when the following system(s)/condition(s) prevent the aircraft from being safely flyable. The aircraft is not capable of day, field flight operations under VMC with two-way radio communication and necessary aircraft and crew safety provisions. The aircraft is NMC, M or S.

AIR CONDITIONING/PRESSURIZATION
AIRFRAME
BOMBING NAVIGATION (INS)
CSC
DECELERATION EQUIPMENT/DROGUE PARACHUTE
ELECTRICAL SYSTEMS
EMERGENCY/PARKING BRAKE
EMERGENCY EQUIPMENT
EMERGENCY RADIO
EMI PROTECTION DEVICES (NOTE 7)
ENGINES
EXPLOSIVE DEVICES
FLIGHT CONTROLS
FLIGHT REFERENCE (NOTE 8)
FUEL SYSTEM (FUSELAGE AND WINGS)
FUSELAGE COMPARTMENTS
HYDRAULIC/PNEUMATIC SYSTEM
ICS (F/A-18B AND F/A-18D)
INSTRUMENTS/INSTRUMENT SYSTEM (WUC 51 SERIES) (NOTE 9)
INTEGRATED GUIDANCE AND FLIGHT CONTROL
(ASN-130 OR ASN-139)
LANDING GEAR
LIGHTING SYSTEMS (ANTI-COLLISION LIGHT (2 MINIMUM))
MAINTENANCE SIGNAL DATA RECORDER SET
MISCELLANEOUS UTILITIES
OXYGEN SYSTEMS/OBOGS
POWER PLANT INSTALLATION
STRAIN GAUGES (NOTE 10)
UHF COMMUNICATION SYSTEMS (1 REQUIRED)
WEAPON CONTROL (HEAD-UP DISPLAY, MULTIPURPOSE
DISPLAY GROUP) (NOTE 3)
WEAPON DELIVERY
CONDITIONAL INSPECTION (NOTE 11)
ENGINE INSPECTION (NOTE 11)
PHASE INSPECTION (NOTE 11)
SPECIAL INSPECTION (NOTE 11)

NOTES:

1. WHEN THE EQUIPMENT IS INSTALLED, REPORT ON THE COMPLETE SYSTEM. WHEN THE EQUIPMENT IS NOT INSTALLED, REPORT ON THE WIRING AND PLUMBING ONLY.
2. NOT APPLICABLE TO VMFA SQUADRONS UNLESS ASSIGNED TO CVW.
3. HUD, LEFT AND RIGHT DDI, KI REQUIRED FOR MISSIONS A, B, C, AND D. HUD AND LEFT DDI REQUIRED FOR MISSIONS J, K AND L.
4. ALL AIR-TO-AIR, ACM, AND AIR-TO-GROUND MODES REQUIRED.
5. EITHER: RADAR BEACON (APN-202 AND RT (1028/APN-202), OR ILS RECEIVER/DECODER (ARA-63) AND RECEIVER TRANSMITTER PROCESSOR (RT-1379/ASW) REQUIRED.
6. ONLY REQUIRED TO BE CODED (L) IF LESS THAN TWO (2) POSITION LIGHTS AND THREE (3) FORMATION LIGHTS ARE OPERABLE ON EACH SIDE OF AIRCRAFT.
7. DUE TO THE RELATIONSHIP OF ELECTROMAGNETIC INTERFERENCE (EMI) TO SAFETY OF FLIGHT, MAINTENANCE OF ALL EMI PROTECTION DEVICES SHALL BE MAINTAINED WITHIN LIMITS SPECIFIED IN THE APPROPRIATE TECHNICAL MANUALS.
8. INCLUDES: AIR DATA COMPUTER EQUIPMENT, MAGNETIC DETECTOR.
9. INCLUDES: PRESSURE ALTIMETER (BOTH STANDBY AND RESET MODES), AIRSPEED INDICATOR, ATTITUDE REFERENCE INDICATOR, VERTICAL SPEED INDICATOR.
10. EITHER THE PRIMARY OR THE BACKUP STRAIN GAUGE, LOCATED IN THE SEVEN STRAIN GAUGE LOCATIONS (WING ROOT, WING FOLD, FORWARD FUSELAGE, RIGHT HORIZONTAL TAIL, LEFT HORIZONTAL TAIL, RIGHT VERTICAL TAIL, LEFT VERTICAL TAIL) MUST BE OPERABLE.
11. AS APPLICABLE PER REFERENCE (C).

STANDARD F/A-18 TROUBLESHOOTING SETUP

IN AN ATTEMPT TO STANDARDIZE THE HORNET FLEET TO A COMMON GROUND COMMUNICATION SET, THE TSB WILL NO LONGER SUPPORT 5 CONDUCTOR CONFIGURATION DATA. THE BELOW ITEMS WILL BE THE SUPPORTED STANDARD SETUP.

HEADSET - DAVID CLARK (#H10-76)

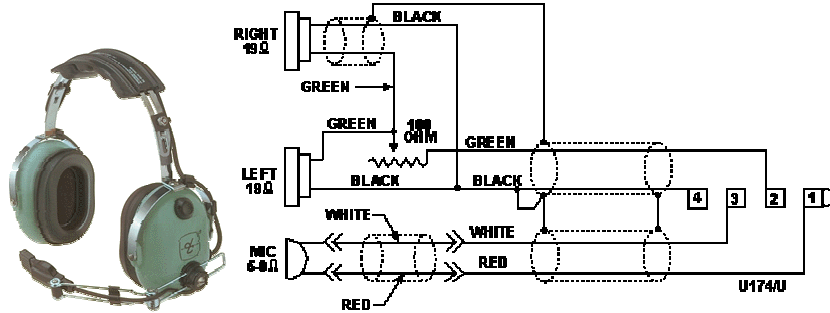

HEADSET (TROUBLESHOOTER) - 4 CONDUCTOR (DAVID CLARK) \$160
 NSN - 5965-01-390-9240
 P/N - H10-76 (DAVID CLARK # 12510G-21) MFG - 71483
 REPLACEMENT MICROPHONE NSN 5965-00-755-4643
 (NOTE - NEW UNIT REQUIRES AN AMPLIFIER NSN 5831-00-100-4932)

GROUND CORD

PICTURED IS A MODIFIED ITEM

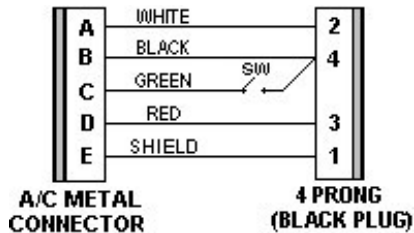

CORD - (10.5 FT WITH CONNECTORS U-94A/U AND MS3107A16S-1P) \$60
 NSN - MADE FROM A 5995-00-705-1349 (CORD WITHOUT RED BUTTON) AND
 5999-01-333-3149 (CONNECTOR)
 P/N - SEE PARTS LIST BELOW
 (NOTE - ALT CORD NSN 5995-00-705-1350 (CORD WITH RED BUTTON))

SEAT-IN CORD

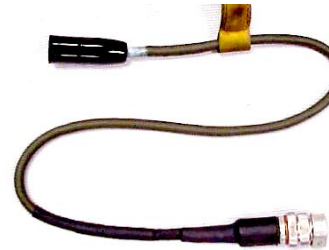

4 PRONG (BLACK PLUG)

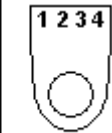

BOTTOM VIEW

SEAT-IN CORD ASSEMBLY \$386
 NSN - 4920-00-969-1373
 P/N - 40916-3 (IMRL LINE#284) MFG - 31441
 (NOTE - ITEM IS CURRENTLY ON IMRL AND DIFFICULT TO PROCURE)

SEAT-OUT CORD

PICTURED IS A MODIFIED ITEM



4 PRONG (BLACK PLUG)

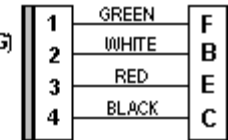

SEAT-OUT CORD ASSEMBLY \$1340
 NSN - MADE FROM A 4970-01-127-8199 (CORD) AND 5935-00-665-5125
 CONNECTOR)
 P/N - CORD P/N 253D900 MFG - 30941
 (NOTE - USE NRFI (BAD OXY LINE) ASSY FROM THE PARALOFT FOR FREE)

GROUND EXTENSION CORD

PICTURED IS A MODIFIED ITEM



A/C METAL CONNECTOR

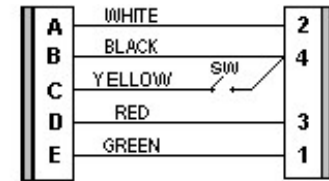

4 PRONG (BLACK PLUG)

EXT CORD - (40 FT WITH CONNECTORS U-94A/U AND MS3107A16S-1P) \$72
 NSN - MADE FROM A 5995-00-610-5723 (CORD) AND 5935-00-276-9390 (PLUG)
 P/N - CORD P/N 5-62887-1 MFG - 54736

SPLITTER (TRAINER) CORD

PICTURED IS A MODIFIED ITEM

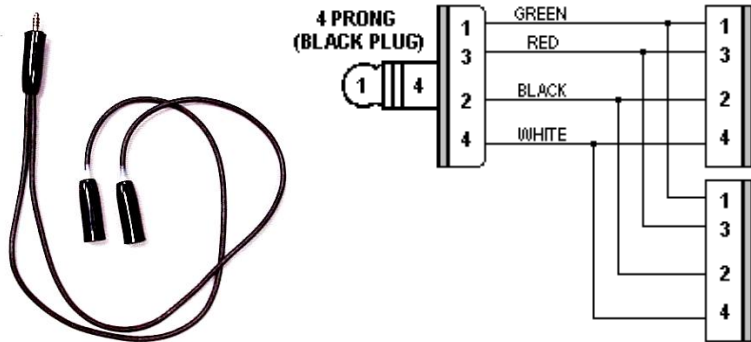

SPLITTER CORD ASSEMBLY
NSN - MADE FROM A 5935-00-642-0626 (MALE) & TWO 5935-00-665-5125 (FEMALE) CONNECTORS
P/N - SEE PARTS LIST BELOW

GROUND CORD ASSEMBLY



GROUND HOT CORD COILED (10.5 FT - NO BUTTON ASSEMBLY) \$60
NSN - 5995-00-705-1349
P/N - 10577A MFG - 18068

GROUND CORD ASSEMBLY



GROUND CORD COILED (10.5 FT - RED PUSH BUTTON ASSEMBLY) \$130
NSN - 5995-00-705-1350
P/N - 127D800-1 MFG - 78711

PLUG - SMALL 4 CONDUCTOR (BLACK)

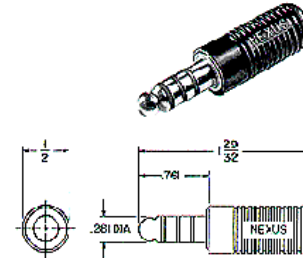

PLUG - BLACK 4 CONDUCTOR MALE \$6
NSN - 5935-00-246-2383
P/N - U-174/U MFG - 81349

PLUG - LARGE 4 CONDUCTOR (BLACK)

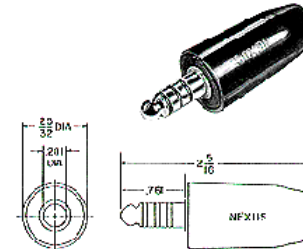

PLUG - BLACK 4 CONDUCTOR MALE \$6
NSN - 5935-00-642-0626
P/N - U-93A/U ALT M9177/1-1 MFG - 81349

JACK - LARGE 4 CONDUCTOR (BLACK)

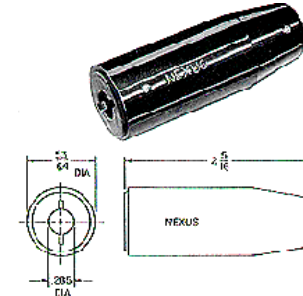

JACK - BLACK 4 CONDUCTOR FEMALE (U/I 5 EA) \$4
NSN - 5935-00-665-5125
P/N - U-92A/U ALT - M9177/3-1 MFG - 81349

SWITCH JACK - 4 CONDUCTOR (BLACK)

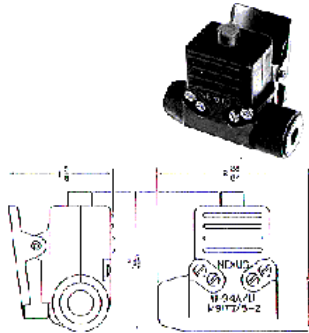

JACK - BLACK 4 CONDUCTOR FEMALE \$13
NSN - 5999-01-333-3149
P/N - U-94A/U ALT - M9177/5-2 MFG - 28986

PLUG - 6 CONDUCTOR (PLUG)



EXTENSION CORD PLUG (6 CONDUCTOR) \$6
NSN - 5935-00-276-9390
P/N - MS3107A16S-1P MFG - 96906

JACK - 6 CONDUCTOR (AIRCRAFT JACK)



EXTENSION CORD JACK \$12
NSN 5935-01-107-8827
P/N MS3470W10-6S MFG - 96906

HARDWARE KIT (DAVID CLARK)



HARDWARE REPAIR KIT (DAVID CLARK HEADSETS) \$44.00
NSN 5340-01-282-5578
P/N 12840G-05 MFG - 71483

EAR SEALS



EAR SEALS - SOFT TYPE (DAVID CLARK) \$6
NSN - 5965-01-207-6523
P/N - 40051G-02 MFG - 71483

AMPLIFIER



AMPLIFIER - AUDIO \$50
NSN - 5831-00-100-4932
P/N - M23595/1-2 MFG - 81349

MICROPHONE



MICROPHONE (M-87) - GROUND TYPE \$25
NSN - 5965-00-755-4643
P/N - M-87/AIC MFG - 81349

MIC SOCK



MIC SOCK (M-87/AIC TYPE) \$5
NSN - 5965-01-438-6928
P/N - 18434G-02 MFG - 71483

BOOM ASSY



BOOM - CHROME ASSY (DAVID CLARK HEADSETS) \$21.38
NSN 5695-01-282-6078
P/N 12765G-04 MFG - 71483

STANDARD CARRIER FLIGHT DECK SETUP

HEADSET - DAVID CLARK (#H3330)

PICTURED IS A MODIFIED ITEM

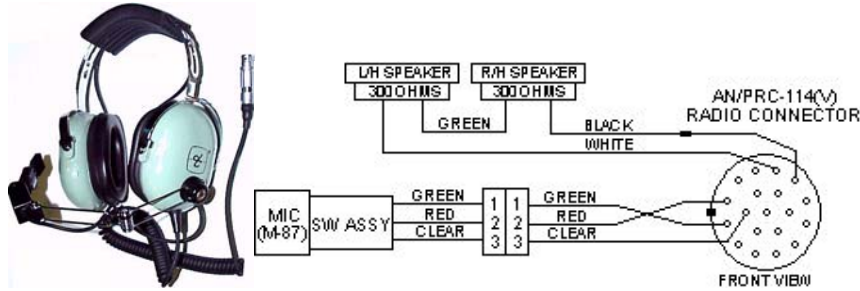

HEADSET (FDC) - 3 CONDUCTOR (DAVID CLARK) \$184.97
 P/N - 12508G-02 ALT H3330 MFG - 71483
 NSN - MADE FROM A 5965-01-394-8660 (STD COMMERCIAL A/C HEADSET),
 5995-01-408-4021 (CORD ASSY KIT TO MODIFY HEADSET TO FIT A
 AN/PRC-114(v) RADIO), 5965-01-282-7760 (SWITCH ASSY),
 5965-00-755-4643 (M-87 MICROPHONE)
 P/N - SEE PARTS LIST BELOW (MIC ABOVE)

CORD ASSY KIT



CORD ASSY KIT (MATES TO AN/PRC-114(v) RADIO) \$263.14
 NSN - 5995-01-408-4021
 P/N - 18028G-43 MFG - 71483

SWITCH ASSY



SWITCH ASSY (USES A STANDARD M-87 MICROPHONE) \$296.81
 NSN - 5965-01-282-7760
 P/N - 18796G-01 MFG - 71483

DIGITAL MAP CD TESTING/CHECKPOINTS

- 1.) INSTALL NEW MAP CD IN DMU (ENSURE COVER IS FULLY CLOSED)
- 2.) GROUND POWER 1 & 2 TO B-ON (LEAVE INS OFF)
- 3.) ON HSI - SELECT HSI, DATA, WAYPOINT O, UFC
- 4.) ENTER COORDINATES FOR DESIGNATED AREA BELOW
- 5.) ON HSI - SELECT A/C (POSITION), UFC
- 6.) ENTER COORDINATES FOR DESIGNATED AREA BELOW
- 7.) DMS BIT, CHECK FOR A MAP ID# BELOW COLOR PATTERN
- 8.) CHECK SCALES (AS APPLICABLE PER DESIGNATED AREA BELOW)

CHECKPOINT COORDINATES:

US EAST COAST (AOD# 004) - SCALES 10/40 - N32°28'10", W80°43'10"
 US WEST COAST (AOD# 003) - SCALES 10/40 - N32°52'00", W117°08'00"
 MED EAST (AOD# 010) - SCALES 10/40 - N40°00'00", E25°00'00"
 MED WEST II (AOD# 024) - SCALES 10/40 - N40°00'00", E05°00'00"
 MED EAST/WEST OVERLAP (AOD# 010/024) - 10/40 - N40°00'00", E15°00'00"
 SOUTH/WEST ASIA (AOD# 117) - SCALES 10/40 - N25°00'00", E40°00'00"
 WEST PACIFIC - NORTH (AOD# 008) - SCALES 10 - N34°08'40", E132°13'55"
 WEST PACIFIC - SOUTH (AOD# 007) - SCALES 10 - N10°00'00", E123°00'00"

OTHER MEMORY INSPECT

(ALL BELOW READINGS ARE MEMORY INSPECTED WITH UNIT# 28, UNLESS OTHERWISE ANNOTATED)

GPS 4 SATELLITES LOCKED IBIL4M (13C - 7033225) BIT 13 LOW	IFF MODE II PREFIX IIASW (13C - 7031463) READ AS OCTAL		FLJR COOLDOWN (POD START) UNIT 7 - 165002442 READY AT 066000
WEIGHT ON WHEELS LMLG ICAD14 (13C - 7036005) BIT 1 HIGH	WEIGHT ON WHEELS NLG ICAD10 (13C - 7036005) BIT 5 HIGH	WEIGHT ON WHEELS RMLG ICAD08 (13C - 7036005) BIT 7 HIGH	
DOWN AND LOCKED LMLG ICAD07 (13C - 7036005) BIT 8 HIGH	DOWN AND LOCKED NLG ICAD11 (13C - 7036005) BIT 4 HIGH	DOWN AND LOCKED RMLG ICAD06 (13C - 7036005) BIT 9 HIGH	
POSITIVE G UNITS PREVPG (13C - 00024356) (15C - 00021373) SEE LMM-030 CHART	ALTITUDE PREVPA (13C - 00024354) (15C - 00021371) SEE LMM-030 CHART	MACH NUMBER PREVPM (13C - 00024357) (15C - 00021374) SEE LMM-030 CHART	A/C GROSS WEIGHT PREVPW (13C - 00024361) (15C - 00021376) SEE LMM-030 CHART

OCTAL TO BINARY CONVERSION CHART

BIT#	15	14	13	12	11	10	9	8	7	6	5	4	3	2	1	0
DATA																
BIT#	2, 5, 8, 11, 14				1, 4, 7, 10, 13				0, 3, 6, 9, 12, 15							
HIGH	4, 5, 6, 7				2, 3, 6, 7				1, 3, 5, 7							
LOW	0, 1, 2, 3				0, 1, 4, 5				0, 2, 4, 6							

EXAMPLE - PADDLE SWITCH READOUT FROM MEMORY INSPECT ADDRESS 4661 (UNIT 14) IS: 765432. FILL IN THE BLANK DATA BLOCKS OF THE UPPER CHART WITH: 765432. BIT 14 IS HIGH WHEN THE PADDLE SWITCH IS PRESSED. FROM THE UPPER CHART, NOTE THE DATA BLOCK FOR BIT 14 EQUALS 6. NOW USING THE LOWER CHART, NOTE THAT BIT# 14 IS IN THE 1ST COLUMN. NOW NOTE FROM THE 1ST COLUMN THAT A DATA VALUE OF 6 IS EQUAL TO BEING HIGH. THEREFORE, THE PADDLE SWITCH IS BEING PRESSED AT THE TIME THE MEMORY INSPECT WAS TAKEN.

SPECIAL BIT DISPLAY

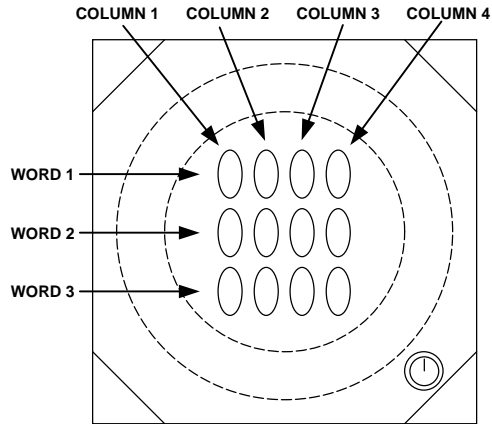

HEXADECIMAL	BINARY	HEXADECIMAL	BINARY
1	0001	9	1001
2	0010	A	1010
3	0011	B	1011
4	0100	C	1100
5	0101	D	1101
6	0110	E	1110
7	0111	F	1111
8	1000		

COLUMN 1 COLUMN 2 COLUMN 3 COLUMN 4

WORD 1 - ALR 67 COMPUTER FAILURES															
BIT 15	BIT 14	BIT 13	BIT 12	BIT 11	BIT 10	BIT 9	BIT 8	BIT 7	BIT 6	BIT 5	BIT 4	BIT 3	BIT 2	BIT 1	BIT 0
PCU DMA	TKR	SIU	IOU DMA	PCU 315°	PCU 225°	PCU 135°	PCU 45°	IPU CKS	MRU 2	PMU 2	CPU 2	MRU 2	PMU 2	CPU 2	NOT USED

WORD 2 - SPECIAL RECEIVER FAILURES															
BIT 15	BIT 14	BIT 13	BIT 12	BIT 11	BIT 10	BIT 9	BIT 8	BIT 7	BIT 6	BIT 5	BIT 4	BIT 3	BIT 2	BIT 1	BIT 0
ALIVE	OVER TEMP	LB BIT	NOT USED	PULS THR	PULS COR	PULS DSC	PULS AMP	NOT USED	PULS DMA	CW THR	IF ATN	CW LOG	CW DMA	SOD	NOT USED

WORD 3 - INTEGRATED ANTENNA AND QUAD RECEIVER FAILURES															
BIT 15	BIT 14	BIT 13	BIT 12	BIT 11	BIT 10	BIT 9	BIT 8	BIT 7	BIT 6	BIT 5	BIT 4	BIT 3	BIT 2	BIT 1	BIT 0
QUAD RF				LOW BAND VIDEO				QUAD VIDEO				IBU FAIL			
315°	225°	135°	45°	315°	225°	135°	45°	315°	225°	135°	45°	NOT USED	REPEAT MODE	#	#

LEGEND:

- # BIT 0 - PORT 1 BLANK FAILURE
- BIT 1 - PORT 2 BLANK FAILURE
- BIT 0 AND BIT 1 - REPEAT TAG FAILURE

F/A-18 EFFECTIVITY MATRIX

LOT	BUY FY	DLV FY	MCAIR # =QTY	BLK	MODEL/CUM# =QTY	MODEL/CUM# =QTY	BUNOs
IV	80	82	21-45=25	5	F-18A/17-19=3	F-18B/5-8=4	161353-161359
				6	F-18A/20-27=8	F-18B/9=1	161360-161519
				7	F-18A/28-36=9		161520-161528
V	81	83	46-124=79	8	F-18A/37-46=10	F-18B/10-13=4	161702-161715
				9	F-18A/47-63=17	F-18B/14-17=4	161716-161736
				10	F-18A/64-86=23	F-18B/18-20=3	161737-161924
VI	82	84	125-211=63	11	F-18A/87-103=17	F-18B/21-23=3	161925-161944
				12	F-18A/104-123=20	F-18B/24=1	161945-161965
				13	F-18A/124-145=22		161966-161987
VII	83	85	212-337=84	14	F-18A/146-163=18	F-18B/25-27=3	162394-162414
				15	F-18A/164-191=28	F-18B/28-29=2	162415-162444
				16	F-18A/192-224=33		162445-162477
VIII	84	86	338-472=84	17	F-18A/225-248=24	F-18B/30-32=3	162826-162852
				18	F-18A/249-273=25	F-18B/33-36=4	162853-162881
				19	F-18A/274-300=27	F-18B/37=1	162882-162909
IX	85	87	473-618=84	20	F-18A/301-324=24	F-18B/38-40=3	163092-163118
				21	F-18A/325-350=26	F-18B/41=1	163119-163145
				22	F-18A/351-380=30		163146-163175
X	86	88	619-757=84	23	F-18C/1-23=23	F-18D/1-8=8	163427-163457
				24	F-18C/24-44=21	F-18D/9-16=8	163458-163486
				25	F-18C/45-61=17	F-18D/17-23=7	163487-163510
XI	87	89	758-866=84	26	F-18C/62-86=25	F-18D/24-26=3	163699-163726
				27	F-18C/87-112=26	F-18D/27-28=2	163727-163754
				28	F-18C/113-137=25	F-18D/29-31=3	163755-163782
XII	88	90	867-958=84	29	F-18C/138-157=20	F-18D/32-41=10	163985-164014
				30	F-18C/158-173=16	F-18D/42-51=10	164015-164040
				31	F-18C/174-191=18	F-18D/52-61=10	164041-164068
XIII	89	91	959-1042=84	32	F-18C/192-208=17	F-18D/62-68=7	164196-164219
				33	F-18C/209-231=23	F-18D/69-75=7	164220-164249
				34	F-18C/232-255=24	F-18D/76-81=6	164250-164279
XIV	90	92	1043-1126=66	35	F-18C/256-277=22		164627-164648
				36	F-18C/278-288=11	F-18D/82-91=10	164649-164669
				37	F-18C/289-301=13	F-18D/92-101=10	164670-164692
XV	91	93	1127-1196=48	38	F-18C/302-313=12	F-18D/102-105=4	164693-164708
				39	F-18C/314-325=12	F-18D/106-109=4	164709-164724
				40	F-18C/326-337=12	F-18D/110-113=4	164725-164740
XVI	92	94	1197-1244=48	41	F-18C/338-346=9	F-18D/114-122=9	164865-164882
				42	F-18C/347-358=12	F-18D/123-125=3	164883-164897
				43	F-18C/359-371=13	F-18D/126-127=2	164898-164912
XVII	93	95	1245-1284=36	44	F-18C/372-377=6	F-18D/128-133=6	164945-164956
				45	F-18C/378-383=6	F-18D/134-139=6	164957-164968
				46	F-18C/384-395=12		164969-164980
XVIII	94	96	1285-1367=36C 7 E/F (EMD)	47	F-18C/396-407=12		165171-165182
				47	F-18E/1-2=2		165164-165165
				48	F-18C/408-419=12		165183-165194
XIX	95	97	1376-1418=24	48	F-18E/3=1	F-18F/1=1	165166-165167
				49	F-18C/420-431=12		165195-165206
				49	F-18E/4-5=2	F-18F/2=1	165168-165170
XX	96	98	1420-1453=18	50	F-18C/432-455=24		165207-165230
XXI	97	99	1454-1498=7 12 E/F (LRIP 1)	51	F-18C/456-465=10	F-18D/140-147=8	165399-165416
				52	F-18C/466=1	F-18D/148-153=6	165526-165532
XXII	98	00	1479-1498=8 20 E/F (LRIP 2)	52	F-18E/6-13=8	F-18F/3-6=4	165533-165544
				53	LOT 21 D CONFIG	F-18D/154-161=8	165680-165687
XXIII	99	01	30 E/F (LRIP 3)	54	F-18E/14-21=8	F-18F/7-18=12	165660-165679
				54	F/A-18E/22-35=14		165779-165792
XXIV	00	02	36 E/F (FRP 1)	55	F/A-18E/36-50=15	F/A-18F/19-34=16	165793-165808
				55	F/A-18E/51-64=14		165860-165874
XXV	01	03	42 E/F (FRP 2)	56		F/A-18F/35-55=21	165875-165895
				56		F/A-18F/56-83=18	165896-165907

HAVE QUICK RADIO INITIATION (GPS):

- 1.) RADIOS - ON
- 2.) PRESS "MENU"
- 3.) PRESS "TRST" TWICE UNTIL "TGPS" APPEARS (IF "TGPS" DOES NOT APPEAR, GPS TIME IS NOT AVAILABLE YET), THE A/C WILL AUTOMATICALLY PERFORM THIS FUNCTION ONE TIME WHEN THE GPS TIME HAS A GOOD QUALITY
- 4.) PRESS "ENTER"
- 5.) PRESS "RTN"
- 6.) ROLL TO A HAVEQUICK CHANNEL
- 7.) SELECT "AJ"
- 8.) PERFORM A RADIO CHECK
- 9.) REPEAT ON OTHER RADIO, IF REQUIRED

HAVEQUICK RADIO INITIATION (NON-GPS):

- 1.) RADIOS - ON
- 2.) SELECT AUTO TOD CHANNEL (CH20)
- 3.) PRESS "MENU"
- 4.) COLONIZE "TRCV" (COLON WILL GO AWAY WHEN TOD IS RECEIVED)
- 5.) PRESS "RTN"
- 6.) ROLL TO A HAVEQUICK CHANNEL
- 7.) SELECT "AJ"
- 8.) PERFORM A RADIO CHECK
- 9.) REPEAT ON OTHER RADIO, IF REQUIRED

SINGGARS RADIO INITIATION:

- 1.) RADIOS - ON
- 2.) KY-58 - ON
- 3.) SELECT A SINGGARS CHANNEL (AUX CH18)
- 4.) ENABLE "AJ"
- 5.) IF "NO FILL" APPEARS, GO TO SINGGARS "NO FILL" PROCEDURE BELOW
- 6.) WITH A GPS A/C, GO TO STEP 11
- 7.) PRESS "MENU"
- 8.) SELECT "TIME"
- 9.) FOLLOWING DATA SHOULD BE ENTERED JUST PRIOR TO A ZULU TIME HACK:
 - A.) ENTER LAST TWO DIGITS OF ZULU JULIAN DAY
 - B.) ENTER TWO DIGIT ZULU HOUR
 - C.) ENTER TWO DIGIT ZULU MINUTE (THE ACTUAL HACK MINUTE)
 - D.) PRESS "ENTER" ON THE TIME HACK (MUST BE ±4 SECS OF TRUE ZULU)
- 10.) PRESS "RTN"
- 11.) SELECT "CPHR", IF REQUIRED
- 12.) PERFORM A RADIO CHECK
- 13.) REPEAT ON PRIME, IF REQUIRED

SINGGARS "NO FILL" APPEARS

- 1.) DISABLE "AJ"
- 2.) PRESS "MENU"
- 3.) SELECT "TRST" (ENABLE WILL APPEAR ON DISPLAY)
- 4.) WITH A GPS A/C, PRESS "TRST" AGAIN ("TGPS" APPEARS)
- 5.) PRESS "ENTER"
- 6.) PRESS "RTN"
- 7.) GO TO STEP "4" OF SINGGARS RADIO INITIATION PROCEDURE

* NOTE - IF TIME IS ENTERED INCORRECTLY, RADIO MUST BE SHUTDOWN FOR 10 SECONDS AND REINITIATED.

FIRE WARNING LIGHT FAILURE INDICATION

○ INDICATES LIGHT ON

● INDICATES LIGHT OFF

FIRE WARNING LIGHT INDICATIONS			TEST A - REPLACE	TEST B - REPLACE
L ENG	APU	R ENG		
●● ●●	●● ●●	●● ●●	* FIRE DETECTION UNIT	**# RIGHT AMAD LOOP B ELEMENT PINS 50 AND 51
●● ○	●● ●●	●● ●●	# LEFT AMAD LOOP A ELEMENT PINS 27 AND 28	
○● ○	●● ●●	●● ●●	FIRE DETECTION UNIT	
●○ ●●	●● ●●	○		## LEFT AMAD LOOP B ELEMENT PINS 28 AND 29
○	●● ●●	●● ●●	FIRE DETECTION UNIT	
●● ●●	●● ●●	○		FIRE DETECTION UNIT
○● ○	●● ●●	○	# RIGHT AMAD LOOP A ELEMENT PINS 49 AND 50	
○	●● ●●	○		FIRE DETECTION UNIT
○● ○	●● ●●	○	FIRE DETECTION UNIT	
○	●● ●●	○	## APU LOOP A ELEMENT PINS 7 AND 8	## APU LOOP B ELEMENT PINS 6 AND 7
○	○	○		FIRE DETECTION UNIT
○● ○	○	○	# LEFT ENGINE AFT LOOP A PINS 36 AND 37	# LEFT ENGINE AFT LOOP B PINS 35 AND 36
○	○	○	# RIGHT ENGINE AFT LOOP A PINS 42 AND 43	# RIGHT ENGINE AFT LOOP B PINS 43 AND 44
○● ○	○	○	FIRE DETECTION UNIT	FIRE DETECTION UNIT
○● ○	○	○	# LEFT ENGINE FWD LOOP A PINS 21 AND 22	
○	○	○●	# RIGHT ENGINE FWD LOOP A PINS 12 AND 13	

* - BEFORE REPLACING COMPONENT, INSPECT FOR OPEN BREAKERS, IF BREAKER ARE CLOSED, CHECK FOR +28VDC ON 4P-R023 PINS 4, 10, 18, 30, 33, 40, AND 48 FOR TEST A OR PINS 5, 31, 39, 46, AND 52 FOR TEST B. IF VOLTAGE IS PRESENT, REPLACE COMPONENT, IF NOT REPAIR WIRING.

% - BEFORE REPLACING ELEMENT, REMOVE CONNECTOR 4P-R023. TEST FOR CONTINUITY BETWEEN 4P-R023 AND PINS LISTED. IF CONTINUITY EXIST REPLACE THE FIRE DETECTION CONTROL UNIT.

- TEST FOR CONTINUITY BETWEEN PINS C AND D OF ELEMENT LISTED, IF NO CONTINUITY REPLACE ELEMENT. IF CONTINUITY EXIST, ISOLATE AND REPAIR DEFECTIVE AIRCRAFT WIRING BETWEEN ELEMENT AND 4P-R023 (FIRE DETECTION CONTROL CONNECTOR).

NOTE - FOR INDICATIONS NOT SHOWN, REPLACE FIRE DETECTION CONTROL UNIT.

HYDRAULIC SYSTEM

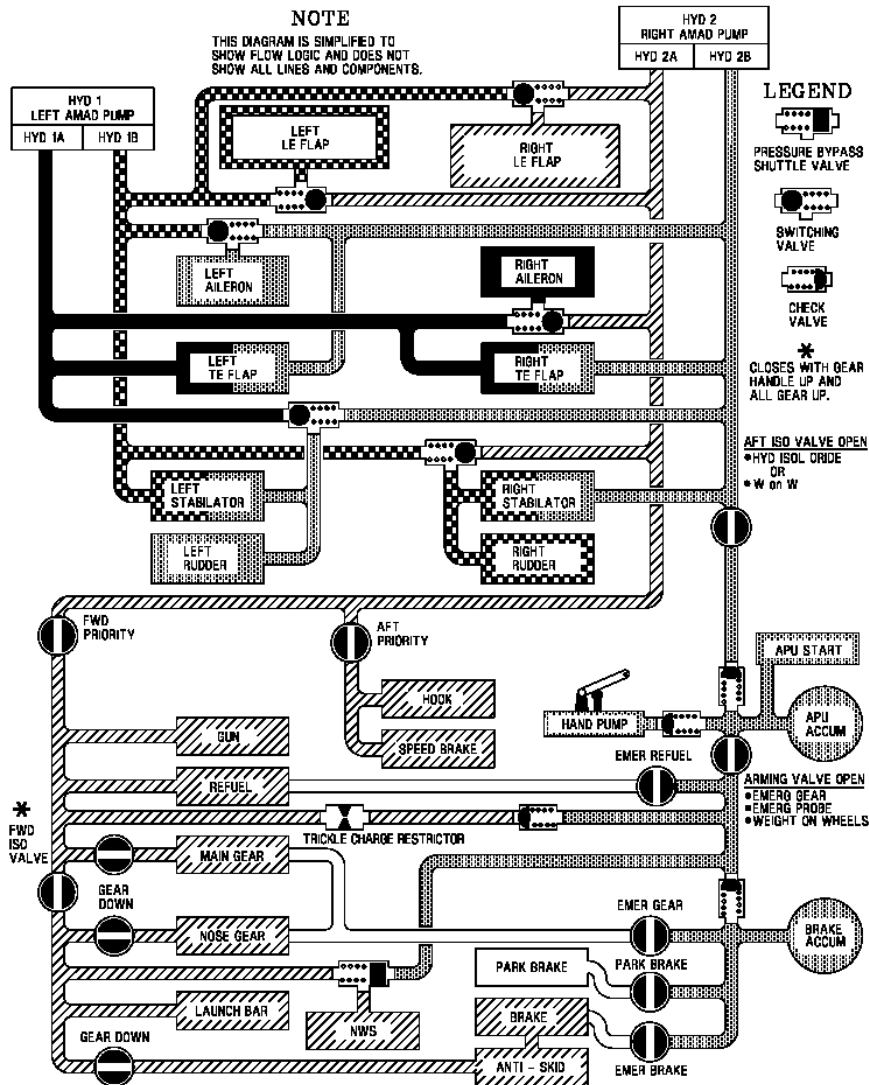

TROUBLESHOOTER SIGNALS

- 1 - AIRFRAMES/AMH/S
- 2 - ELECTRIC/AE
- 3 - POWERLINE/AD
- 4 - ALSS/PR
- 5 - SEATSHOP/AME

- 6 - ORDNANCE/AO
- 7 - COM/NAV/RAD/IWT/AT
- 8 - QA
- 9 - MC/FDC

RELEASED VERSIONS:

- 1 - 890526 - VER 1.0 - HAND COMPILED
- 2 - 900915 - VER 2.2 - "C/D" ADDITIONS
- 3 - 921215 - VER 3.0 - (PRINT SHOP CONVERSION) MMP ADDITIONS
- 4 - 930515 - VER 3.1 - (PRINT SHOP PRO CONVERSION) ENG SCHEMATICS
- 5 - 930815 - VER 4.0 - ADDED HEADSETS AND GND CORDS SCHEMATICS
- 6 - 940701 - VER 5.0 - (AMIPRO 3.0 CONVERSION)
- 7 - 941201 - VER 5.1 - BOA CODE ADDITIONS (AMIPRO 3.1), AFFECTED PAGES 1, 10, 25-31
- 8 - 990307 - VER 6.0.E - REWRITE WITH FULL CODE UPDATES AND ADDITION OF APG-73
- 9 - 990307 - VER 6.0.E - SUPPLEMENT #1 (DATED 991018) ADDED AND PAGE 33 UPDATED
- 10 - 991215 - VER 7.0.A - (Word 97 CONVERSION) AND FULL UPDATES
- 11 - 010315 - VER 8.0.C - (Word 2000 CONVERSION) AND FULL UPDATES
- 12 - 010501 - VER 8.0.D - UPDATED PAGES 1, 34, 37, 45 AND ADDED PAGES 42, 43, 44
- 13 - 010815 - VER 8.0.E - UPDATED PAGES 1, 9, 10, 45
- 14 - 020314 - VER 8.1.C - REWRITE WITH FULL CODE UPDATES FOR 15C OFF
- 15 - 060615 - VER 8.1.D - WEB/EMAIL UPDATES, ADOBE CONVERSION, TG 8/9 FIXED ON TITLE PAGE

RELEASE 14 & 15 ARE NO DIFFERENT
RELEASE 16 WILL BE A FULL REVIEW & UPDATE
SEND IN YOUR INPUTS!!!

Written in Microsoft® Word 2000 (v9.0.6926 SR-3)
Contains 50 Pages

TSB™ v8.1.D.

FILE MODIFIED DATE - 6/15/05

(NOTE - IF THE FILE MODIFIED DATE DOES NOT MATCH FILE CREATED DATE, YOUR VERSION MAY BE MODIFIED AND NOT ACCURATE)

Point of Contact - Webmaster@MayPrinting.com
Look for updates at - <http://MayPrinting.com>

DESIGNED FOR BLUE 5 RING BINDER, 25 PAGES (NSN 7510-00-766-4269)

TO CUT PAGES TO 4-7/8"W x 7-7/8"L, FOLD 8-1/2" x 11" PAPER DOWN MIDDLE AND TRIM 5/8" FROM OPEN END AND BOTTOM EDGE

Always Use Technical Publications for All Maintenance, this is ONLY a Quick Reference Aid.